



RESEARCH ARTICLE - ENGINEERING (MISCELLANEOUS)

Power Loss Reduction and Reliability Improvement of Radial Distribution Systems Using Optimal Capacitor Placement Technique

Mohanad Muneer Yaqoob^{1*}, Ali Nasser Hussain¹, Wathiq Rafa Abed², Daniel Augusto Pereira³

¹Electrical Engineering Technical College, Middle Technical University, Baghdad, Iraq

²Institute of Medical Technology / Baghdad, Middle Technical University, Baghdad, Iraq

³Universidade Federal de Lavras, Lavras, Brazil

* Corresponding author E-mail: muhaned.iq1997@gmail.com

Article Info.

Abstract

Article history:

Received
30 January 2023

Accepted
16 April 2023

Publishing
31 March 2024

Improving reliability and power quality in Radial Distribution Systems (RDS) is of large significance to ensure the provision of electricity within a reliable and acceptable standard to consumers with increasing load requirements. An Optimal Capacitor Placement (OCP) technique is used in the present work to achieve the highest power quality and system reliability in a balanced manner at the same time. The proposed technique has been tested with 69 typical IEEE RDS buses using the Improved Binary Particle Swarm Optimization (IBPSO) algorithm. The proposed algorithm shows a high ability to find the best location and size of injected capacitors inside the RDS to implement a single-objective function for minimization of Active Power Loss (APL). The simulation results obtained from the MATLAB environment show that the OCP technique has a significant potential to enhance RDS reliability, bus voltage, and loss reduction as compared to other previous work.

This is an open-access article under the CC BY 4.0 license (<http://creativecommons.org/licenses/by/4.0/>)

Publisher: Middle Technical University.

Keywords: Radial Distribution Systems; Power Quality; Improved Binary Particle Swarm Optimization; Optimal Capacitor Placement; Reliability Assessment.

1. Introduction

Distribution systems are the vital link in supplying customers with electricity. The effectiveness of a reliable distribution system in consistently providing safe power to customers is determined. Due to their shorter length, distribution lines have a high resistance to reactance ratio (R/X), which results in a large APL. The percentage of APL in distribution systems is approximately 70% of the total losses in electrical power systems [1-3]. In general, distribution systems are designed to operate in radial form, as it is suitable for many operations such as voltage control and protection. Many solutions have been used to improve the performance of the distribution system such as Optimization of Distributed Generators, OCP and Distribution System Reconfiguration [4]. OCP help reactive power compensation, APL reduction, and enhancement voltage profile [5]. Many studies have been presented on OCP applied for the various RDSs with different objective functions and constraints. For example, Sirjani and Badiossadat applied the Ant Colony Optimization (ACO) method to solve the OCP problem for IEEE-9 bus RDS. The proposed algorithm succeeds in implementing the objective function is for finding the location and size of OCP to maximize the saving due to the APL reduction [6]. To prove the effect of adding OCP in larger RDS, Sultana and Roy proposed the Teaching-Learning Based Optimization (TLBO) algorithm for IEEE- 22, 69, 85 and 141 bus RDSs for minimization both of APL and the total cost while satisfying all operational constraints [7]. A new method for placement and sizing capacitors was introduced by Lotfi et al. It is based on combining two algorithms, the Shuffled Frog-Leaping Algorithm (SFLA) and PSO, which is called the Improved PSO Algorithm (IPSO). Minimizing costs while reducing APL and maintaining voltages within permitted ranges is the major goal for researchers. The proposed method is tested in IEEE-34 bus RDS and results are very promising [8]. Two modern algorithms, Qualified BPSO (QBPSO) and Modified Grey Wolf Optimization (MGWO), to handle the performance of the RDS using OCP have been presented by Kadom et al. A triple objective function was implemented to reduce the total APL, improve the voltage profile, and reduce the cost by increasing the annual savings ratio. Both algorithms were applied to IEEE-33 bus RDS under three different load conditions: constant, light, and heavy. The results obtained using Matlab program indicate the success of the proposed algorithms in implementing the set objective function by finding the best location and size of the capacitor to achieve the desired purpose [9]. In addition, Jahromi et al succeeded in determining the optimal location and size of capacitors injection. To enhance the voltage profile and reduced APL for both IEEE-34 constant and variable load conditions using the Honeybee Mating Optimization (MHBMO) algorithm [10]. In the previous literature, the researchers focused on improving the voltage profile and reducing the APL without considering the effect of network reliability because of this optimization process. The reliability is very important in a power system as reliability

Nomenclature & Symbols			
RDS	Radial Distribution Systems	SAIDI	System Average Interruption Duration Index
OCP	Optimal Capacitor Placement	SAIFI	System Average Interruption Frequency Index
IBPSO	Improved Binary Particle Swarm Optimization	CAIDI	Customer Average Interruption Duration Index
APL	Active Power Losses	ASAI	Average Service Availability Index
NRM	Newton Raphson Method	EENS	Expected Energy Not Supplied
GSM	Gauss- Seidel Method	AENS	Average Energy Not Supplied
DBFSM	Direct Backward Forward Sweep method	ASUI	Average Service Unavailability Index

assessment helps in planning the system in the long term [11]. Therefore, in this work, to avoid the disadvantages found in previous literature, the OCP technique is used to implement a single objective function to reduce the total APL of the system while optimizing the voltage profile and ensuring better system reliability as a prerequisite for the optimization process. The IBPSO algorithm is applied for IEEE-69 bus RDS to determine the optimal location and size of the capacitors.

2. Materials and Methods

This section discusses the load flow method proposed in this research and the proposed objective function with the constraints used in optimizing the system, mentioning the reliability evaluation indicators used in this study and the proposed algorithm to be applied as follows:

2.1. Load flow

Load flow methods are one of the most important numerical tools for power system planning and development. The steady state of power systems is provided by load flow analysis [12]. In contrast to transmission systems, distribution systems use conductors that have a high (R/X) ratio. Therefore, Transmission grid load flow methods or Jacobian-based methods, such as Newton Raphson Method (NRM), Gauss- Seidel method (GSM) and fast-decoupled method (FDM), failed with distribution networks. Even with some advancements in the NRM, the program's robustness is obtained, but the computational time is still considerable [13]. As a result, other methodologies, such as the Direct Backward Forward Sweep method (DBFSM) are more advanced and suitable for an RDS. Moreover, the value of tolerance is set equal to $1 * 10^{-6}$. The steps of the DBFSM load flow have been demonstrated in [14].

2.2. Objective functions

A single objective function is used in this work to minimize the APL. The objective function can be represented mathematically as following [15].

$$\text{minimize } P_{total} = \sum_{y=1}^N |I_{yj}|^2 R_y \quad \text{KW} \quad (1)$$

where P_{total} is the total APL, N all RDS branches, I_{yj} is the current between the buses y and j , R_y is the resistance of branch y .

2.3. Reliability assessment

The distribution system is an important part of the total electrical supply system. The reliability of the system is evaluated using two methods: historical evaluation and predictive evaluation. The reliability of the distribution system is defined as the ability of this system to provide high-quality service for customers. Several standard indices are used to evaluate the reliability due to their profound impact on utility profits, they are essential for improving the power quality of the RDS. The calculations below represent specific customer-oriented performance indices to compute sustained interruption indices [15, 16]. Seven indices are studied in this work to measure the reliability of the RDS as follows:

- SAIDI: System Average Interruption Duration Index.

$$SAIDI = \frac{\text{Total duration of all interruption}}{\text{Total number of customers connected}}$$

$$SAIDI = \frac{\sum_{j=1}^k U_j N_j}{\sum_{j=1}^k N_j} \left(h_r / C \cdot y_r \right) \quad (2)$$

where N_j number of customers at load point j , U_j outage time, and $C \cdot y_r$ customers connected in the year.

- SAIFI: System Average Interruption Frequency Index.

$$SAIFI = \frac{\text{Total number of all interruptions}}{\text{Total number of customers connected}}$$

$$SAIFI = \frac{\sum_{j=1}^k \lambda_j N_j}{\sum_{j=1}^k N_j} \left(f / C \cdot y_r \right) \quad (3)$$

Where λ_j failure rate and f frequency interruption.

- CAIDI: Customer Average Interruption Duration Index.

$$CAIDI = \frac{\text{Total duration of all interruption}}{\text{Total number of all interruptions}}$$

$$CAIDI = \frac{\sum_{j=1}^k U_j N_j}{\sum_{j=1}^k \lambda_j N_j} (h_r) \quad (4)$$

- ASAI: Average Service Availability Index.

$$ASAI = \frac{\text{Total number of hours availability}}{\text{Total demand hours}}$$

$$ASAI = \frac{\sum_{j=1}^k 8760 N_j - \sum_{j=1}^k U_j N_j}{\sum_{j=1}^k 8760 N_j} (P.U) \quad (5)$$

- EENS: Expected Energy Not Supplied.

$$EENS = \sum_{j=1}^k L_j U_j (MWhr/y_r) \quad (6)$$

where L_j average value of load connected to feeder j .

- AENS: Average Energy Not Supplied.

$$AENS = \frac{\text{Total enerage not supplie}}{\text{Total number of customers connected}}$$

$$AENS = \frac{\sum_{j=1}^k EENS}{\sum_{j=1}^k N_j} (MWhr/C.y_r) \quad (7)$$

- ASUI: Average Service Unavailability Index.

$$ASUI = 1 - ASAI \quad (8)$$

2.4. System constraints

For better performance of the RDS, several constraints and limitations are adopted. The following are the main constraints taken into account in this search:

2.4.1. Voltage Limit

The voltage magnitude of all buses of the system is maintained within the normal limit of improvement, where the minimum value of voltage is $V_{min} = 0.95 p.u$ and maximum value is $V_{max} = 1 p.u$.

$$V_{min} \leq V_i \leq V_{max} \quad (9)$$

2.4.2. Current Limit

The value of current between the branches must be maintained within the allowable thermal limit.

$$|I_i| \leq I_{i,max} \quad (10)$$

2.4.3. Capacitor Size

The maximum reactive power of capacitors that injected into the RDS $Q_{C,MAX}$ must be less than total reactive power of the load Q_L as the following equation.

$$Q_{C,MAX} < Q_L \quad (11)$$

2.4.4. Reliability constraints

Improving reliability indices better than the base case is included as a prerequisite for the improvement process, as shown in the equations below:

$$0 < SAIDI < (SAIDI)_B \quad (12)$$

$$0 < SAIFI < (SAIFI)_B \quad (13)$$

$$0 < CAIDI < (CAIDI)_B \quad (14)$$

$$0 < AENS < (AENS)_B \quad (15)$$

$$ASAI > (ASAI)_B \quad (16)$$

$$0 < EENS > (EENS)_B \quad (17)$$

$$0 < ASUI > (ASUI)_B \quad (18)$$

where $(SAIDI)_B$, $(SAIFI)_B$, $(CAIDI)_B$, $(AENS)_B$, $(ASAI)_B$, $(EENS)_B$ and $(ASUI)_B$ are represented the indices in base case, and SAIDI, SAIFI, CAIDI, AENS, ASAI, EENS and ASUI are indices after optimization.

2.5. IBPSO Algorithm

In 1995 Kennedy and Eberhardt proposed the PSO algorithm, which simulates the collective intelligence of flocks of birds and fish. This algorithm relies on communities or swarms formed by random solutions called particles, as each particle in this algorithm is linked to velocity and these particles fly across the search area at varying speeds from one area to another according to the behaviour of these particles [17], as the Each particle has its own speed and position that can be set, and the particle has the ability to change its position by searching for a better area within the search process [18]. However, this algorithm in its initial form contained many drawbacks such as easy slippage in local optimization and a lack of strong solutions to discrete optimization problems. In 1997, Kennedy and Eberhart proposed binary PSO algorithms. The binary PSO algorithm works on two-dimensional search regions, where the particles are represented in binary space and the locations of these particles can take binary values of (1, 0). Several problems have emerged with this approach. The previous data of the particles is not used in the subsequent iteration, in addition to changing their locations randomly, which results in insufficiently satisfactory results. So, the IBPSO algorithm was developed in [19] to address these shortcomings. In the IBPSO algorithm, particles start their journey through a small string at a random location in the search space and try to get closer to the global best and previous best. The following equation shows the process of producing a new site for a selected swarm member:

$$v_{j,d}^{t+1} = w_1 \otimes (pbest_{j,d}^{t+1} \oplus x_{j,d}^t) + w_2 \otimes (gbest_{j,d}^{t+1} \oplus x_{j,d}^t) \quad (19)$$

where ' \oplus ', ' \otimes ', and ' $+$ ' represent AND, XOR, and OR operators, respectively, w_1 and w_2 denote the weights of the inertia constants, $v_{j,d}^{t+1}$ represents a particle's velocity for iteration, $t+1$, and dimension d , and $gbest_{j,d}^{t+1}$ and $pbest_{j,d}^{t+1}$ are the best global and best position for particle j , dimension d .

Moreover, the position of the new updated particle, $x_{j,d}^{t+1}$ is written as follows :

$$x_{j,d}^{t+1} = x_{j,d}^t \oplus v_{j,d}^{t+1} \quad (20)$$

All parameters of the IBPSO algorithm are set according to Table 1 .

Table 1. Proposed IBPSO Algorithm Parameters

Parameter	Value
Number of initial populations, P	5
Number of iterations, MAX_{iter}	50
Acceleration constants C_1 and C_2	2
Maximum inertia weight W_{max}	0.9
Minimum inertia weight W_{min}	0.4

The procedures of the work based on proposed IBPSO show in "Fig. 1".

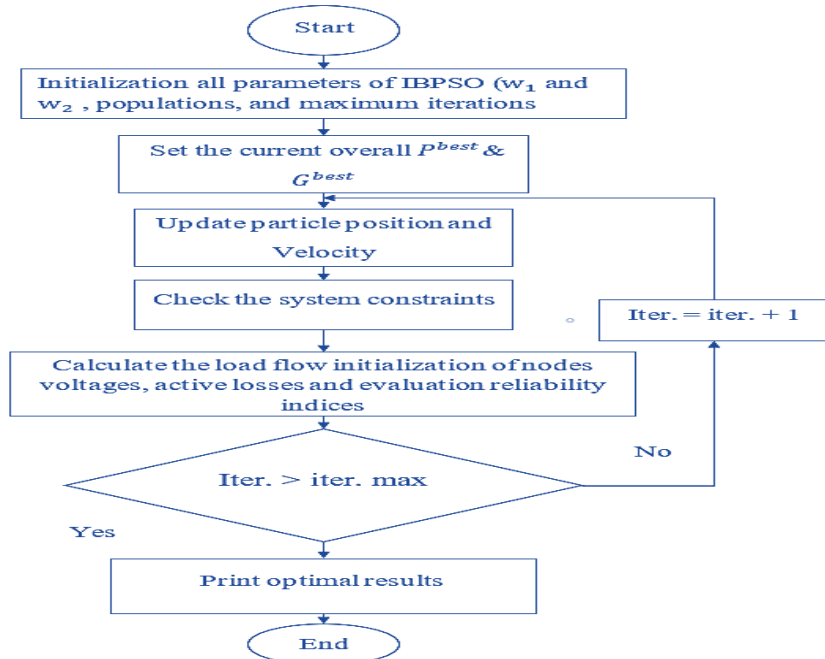

Fig. 1. Flowchart of the IBPSO algorithm

3. Results and Discussion

In this part of the research, the results obtained by implementing the IBPSO algorithm are listed using the MATLAB program to find the optimal location and sizing of the capacitor. This test was carried out on IEEE 69-bus as illustrated in Fig. 2.

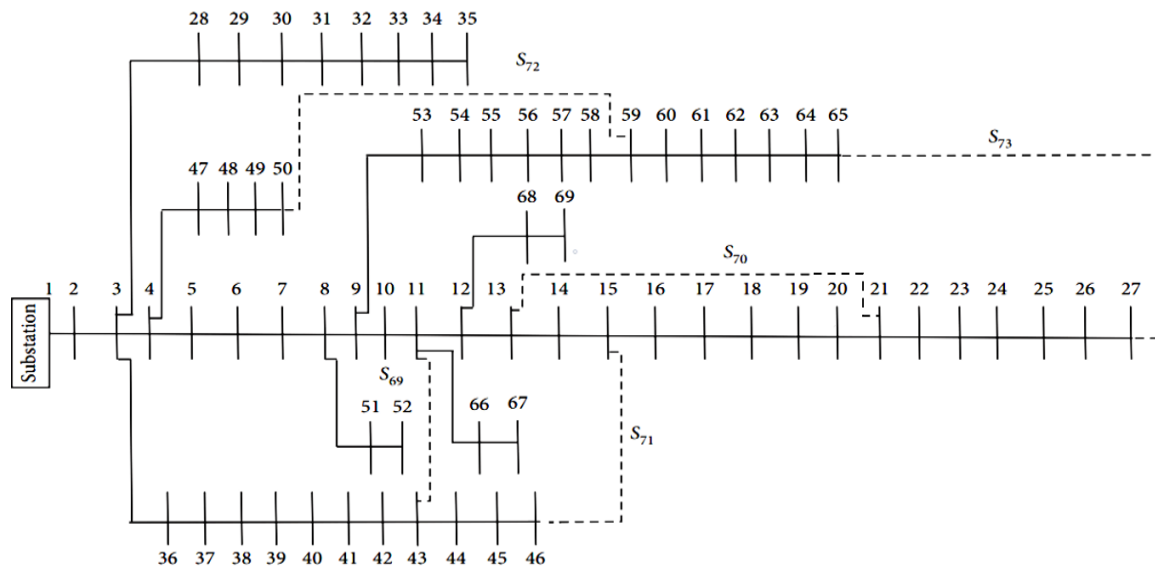

Fig. 2. IEEE 69-bus RDS

This is a standard RDS with 100 MVA, 3.8015 MW, 2.6946MVAR and 12.66 kV which contained 73 branches. The system included 5 opened tie switches (shown by dotted lines) and 68 closed sectionalizing switches (shown by solid lines). The data for this system was taken from [20]. The results of the optimization process are listed in Table 2, which contains (APL of the system, minimum and maximum voltage profile, location and size of capacitors added to the system and reliability indices).

Table 2. Results of a 69-bus RDS using the OCP techniques based on IBPSO

Parameter	Studied Cases	
	Base case	OCP
Tie Switch Number	69, 70, 71, 72, 73	69, 70, 71, 72, 73
Total Power Loss (KW)	224.9606	114.7117
Capacitor Location	-----	18, 39, 61
Capacitor Size (KVAR)	-----	300, 300, 900
Minimum Voltage (p.u)	0.90901	0.95
Maximum Voltage (p.u)	1	1
Execution Time (s)	2.2828	360.7668
Convergence Iterations	----	48
Percentage Loss Reduction	---	49.0081
SAIDI (hr/c.yr)	1.0086	0.98747
SAIFI (f/c.yr)	1.5354	1.5223
EENS (MWhr/yr)	8.3287	7.7437
AENS (MWhr/C.yr)	0.00066897	0.00062199
ASAI (p.u)	0.99988	0.99989
CAIDI (hr / c.Int.)	0.65691	0.64867
ASUI (p.u)	0.00011514	0.00011272

According to the results of Table 2, Fig. 3 shows the location and sizing of OCP injected into the 69-bus RDS after applying the OCP technique using IBPSO.

APL is reduced from 224.9606 kW to 114.7117 kW according to the objective function. Fig. 4 shows the APL curve of bus 69 after implementing the OCP technique compared to the base case which shows a significant improvement. The effect of injecting capacitors is shown in Fig. 5 by compensating the reactive power of RDS. This contributes to the improvement of the voltage profile as shown in Fig. 6. The lowest voltage value is 0.95 p.u. and the highest value is 1 p.u according to established constraint in the equation (9). Furthermore, the convergence curves of APL reduction for the proposed algorithm using OCP technique versus 50 iterations are shown in Fig. 7.

Reliability indices also show a marked improvement over the base case as shown in Fig. 8. This means that the proposed algorithm can perform the optimization process accurately by selecting the optimal location and size of the capacitors that have been added to the system to achieve the intended goal, taking into account the realization of all system constraints.

According to the reliability results, after the improvement process, the duration and frequency of power outages were reduced, contributing to increasing the strength and safety of the energy system in supplying electricity to consumers as a result of reducing AENS and EENS.

However, in Table 3, the proposed IBPSO-based OCP technique was compared with various optimizations that have been published recently, including the locust search (LS) [21], Gravitational Search Algorithm (GSA) [22], Modified Imperialist Competitive (MIC) algorithm, Modified Bacterial Foraging-Based Optimization (MBFBO) algorithm, Cuckoo Search (CS) algorithm, Modified Biogeography-Based Optimization (MBBO) [4]. To prove the effectiveness of the proposed algorithm.

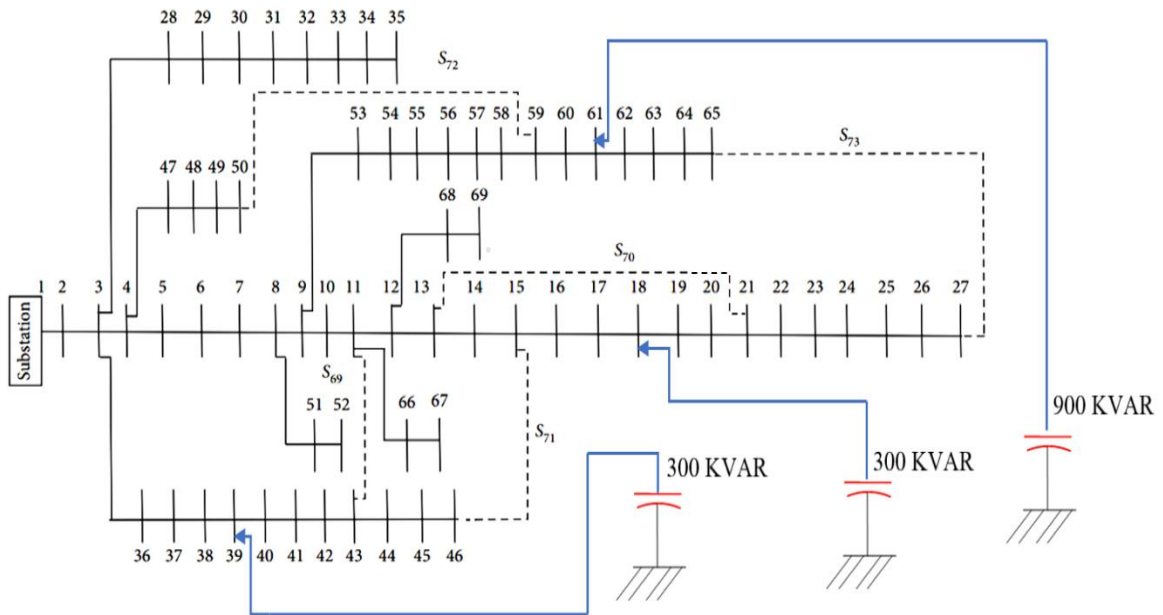

Fig. 3. IEEE 69-bus RDS after optimization process

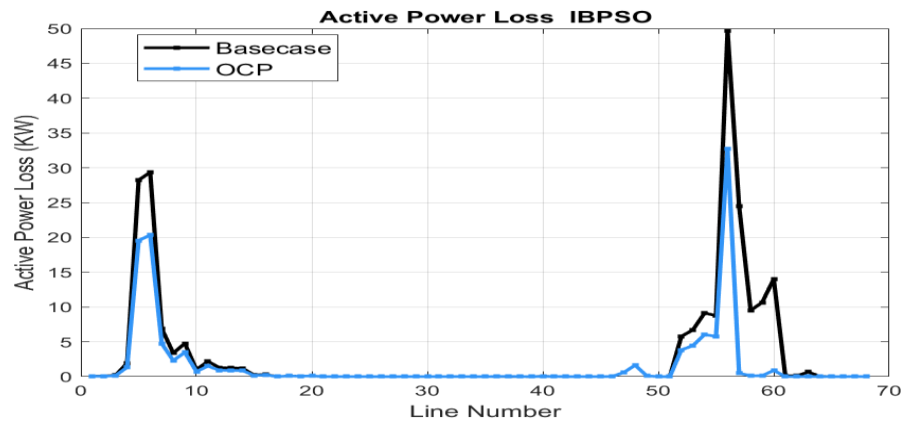

Fig. 4. APL curve for 69-bus with using IBPSO algorithm for OCP technique with base case

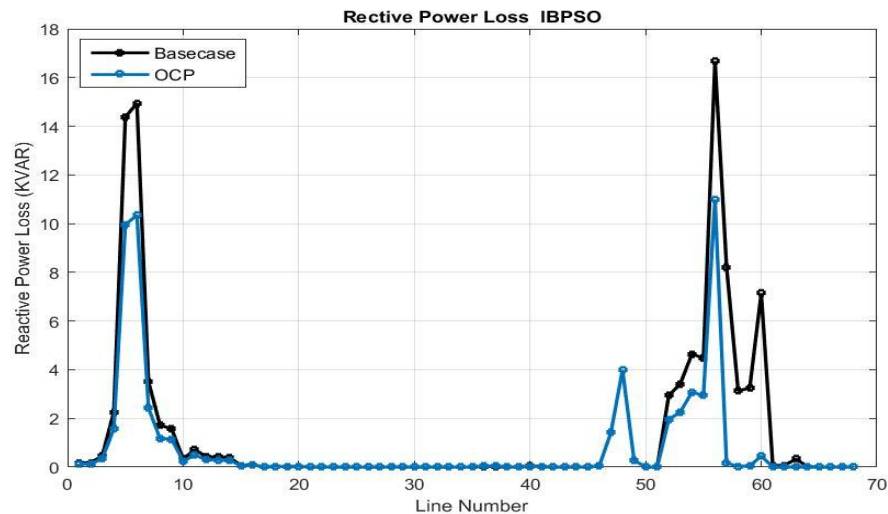

Fig. 5. Reactive power loss curve for 69-bus using IBPSO algorithm for OCP technique with base case

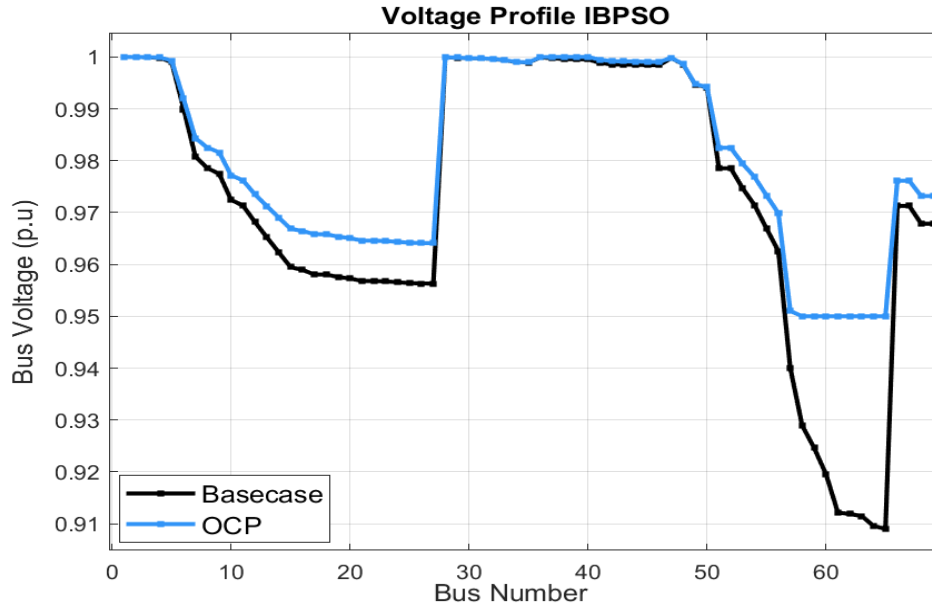

Fig. 6. Voltage profile using IBPSO algorithm for OCP technique with base case

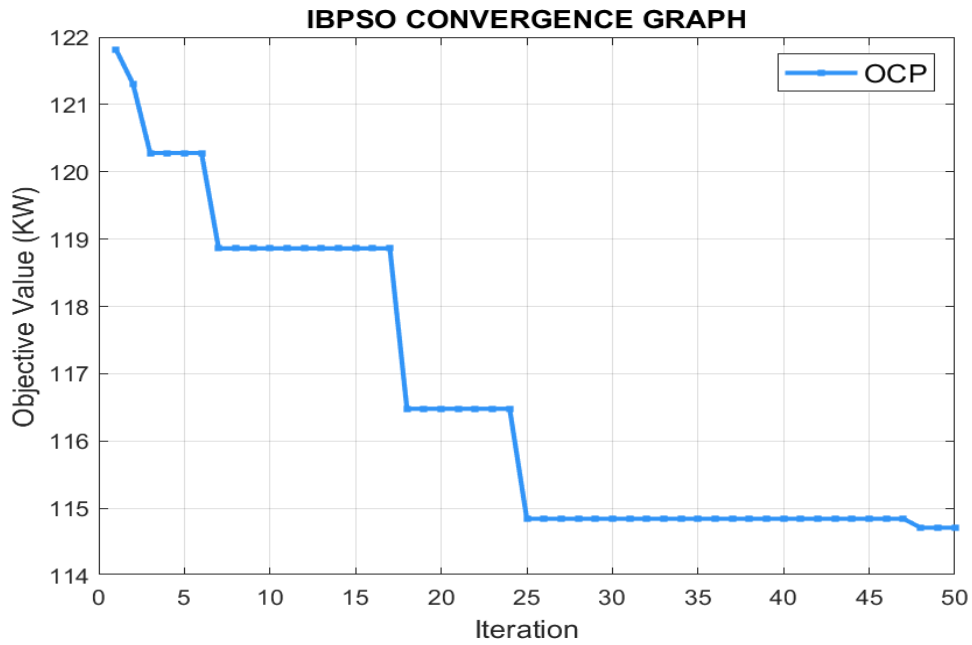
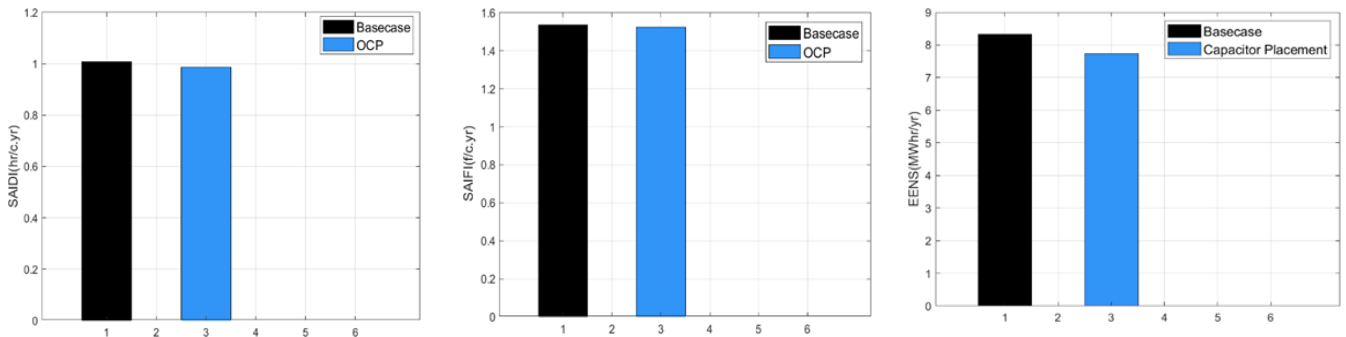

Fig. 7. Convergence of APL (kW) using the suggested IBPSO algorithm



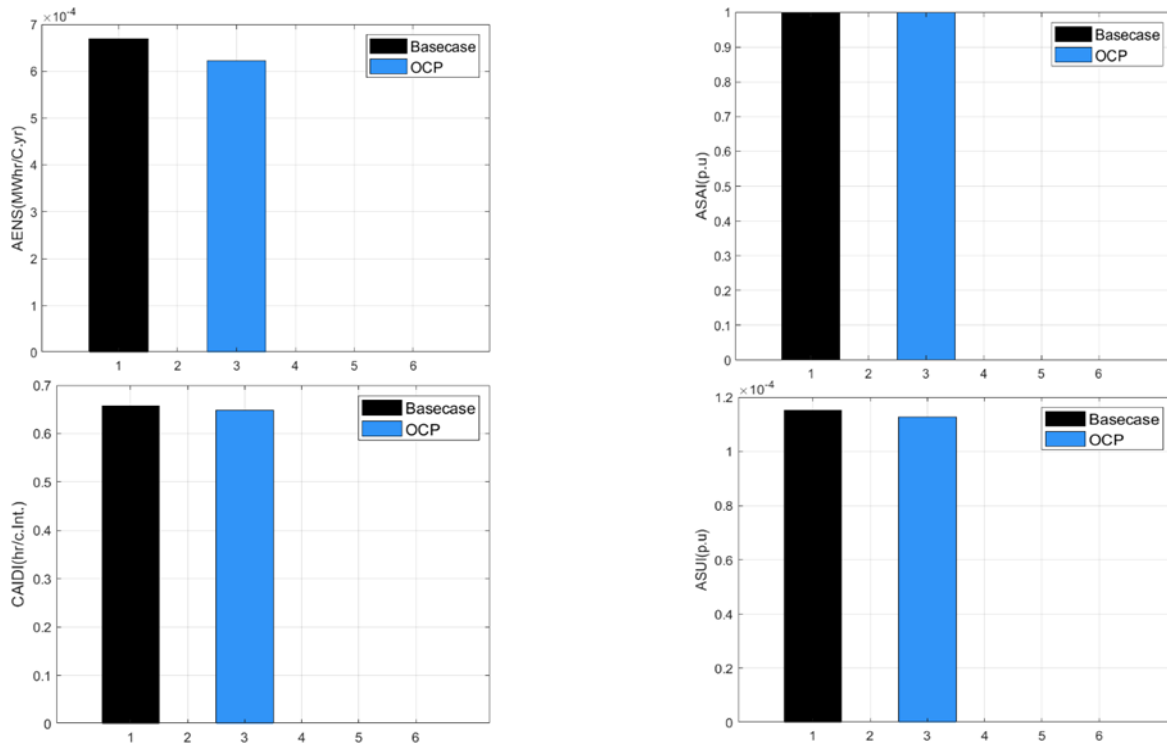

Fig. 8. Reliability indices for a 69-bus system using the IBPSO algorithm for the OCP technique with the base case.

Table 3. Comparison between the IBPSO and other algorithms

Parameter	Literature work Algorithm						Proposed Algorithm IBPSO
	LS [21]	GSA [22]	MIC [4]	MBFBO [4]	CS [4]	MBBO [4]	
Location of OCP	17, 61	26, 13, 15	59, 69, 15	59, 68, 20	15, 50, 61	12, 60, 21	39, 18, 61
Capacitor size (KVAR)	350, 1200	150, 150, 1050	1350, 150, 450	600, 300, 300	450, 600, 900	300, 900, 150	300, 300, 900
Total Power Loss (kW)	146.61	145.9	120.6084	101.8766	90.8139	61.5959	114.7117
V_{min} (p. u)	0.93	0.9519	0.9501	0.9550	0.9600	0.9600	0.95
V_{max} (p.u.)	1	1	1	1	1	1	1
% Loss reduction	34.8285	35.1441	46.3869	54.7131	59.6312	72.6192	49.0081

According to Table 3, the results of this research show a discrepancy compared to the results of other algorithms in previous literature. This difference and discrepancy result from the absence of a limitation on improving network reliability in previous research. So, the IBPSO algorithm shows its efficiency in reducing system APL better than the LS, GSA and MIC algorithms. The superiority of the proposed algorithm can be explained by its high ability to choose the best location and size for injecting capacitors into the system, which reduces losses to the lowest possible value according to the objective function in this work.

Moreover, the limitations on improving reliability indicators play an important role in this research, which is a point of difference. This is prominent from previous research, so the process of optimizing losses is done while maintaining this constraint. This explains the superiority of the algorithms MBFBO, CS, and MBBO over the algorithm proposed in this research, where the losses were reduced more effectively, but this process was done with neglect of the state of network reliability, which could be worse than it was before the optimization process, as previous researchers did not discuss this matter. Therefore, in this work, the loss optimization process was carried out in a balanced manner between the improvement of the APL as a main objective of the research, with the improvement of the effort profile and reliability as a prerequisite for the process.

4. Conclusion

In this research, the IBPSO algorithm was applied for 69-bus IEEE RDS to select the best location and sizing of capacitors. The simulation results acquired using MATLAB software demonstrated that the suggested method could implement the objective function to reduce the APL of RDS. Where the percentage of APL reduction has been raised to 49.0081%. The results also indicated that the implementation of the constraints is preserved, as the process of choosing the optimal location and size of the condensers was carried out according to two basic constraints. The first is to ameliorate the voltage profile of all system buses, as it recorded the lowest voltage value of 0.95 p. u and the highest value of 1 p. u according to the pre-established condition. The second constraint is a complete enhancement of the reliability of the network. Comparison to the base case, the reliability indices SAIDI, SAIFI, EENS, AENS, CAIDI and ASUI are minimized to (0.98747 hr/c. yr, 1.5223 f/c. yr, 7.7437 MWhr/yr, 0.00062199 MWhr/C. yr, 0.64867 hr / c. Int, 0.00011272 p. u) respectively and ASAI index is maximized to (0.99989 p. u). This optimization can increase the energy provided to customers by reducing frequent outages.

Based on the results of this study, the following studies can be conducted as a possible extension in the future:

- A study to apply the proposed techniques and algorithms for real distribution systems when the required data of these systems is available.
- A study to apply the proposed algorithms and techniques for unbalanced and composite load type RDSs.

Acknowledgment

The authors would like to acknowledge the cooperation and assistance they received from Electrical Engineering Technical College to complete this research

References

- [1] L. Goel, and R. Billinton, "Determination of reliability worth for distribution system planning," IEEE Transactions on Power Delivery, vol. 9, NO. 3, pp. 1577 - 1583, July 1994, <https://doi.org/10.1109/61.311207>.
- [2] M. R. Babu, C. V. Kumar, and S. Anitha, "Simultaneous Reconfiguration and Optimal Capacitor Placement Using Adaptive Whale Optimization Algorithm for Radial Distribution System," Journal of Electrical Engineering & Technology, vol. 16, NO. 1, pp. 181-190, November 2020, <https://doi.org/10.1007/s42835-020-00593-5>.
- [3] M. H. M. Jahromi, P. Dehghanian, M. R. M. Khademi, and M. Z. Jahromi, "Reactive Power Compensation and Power Loss Reduction using Optimal Capacitor Placement," 2021 IEEE Texas Power and Energy Conference (TPEC), 2021, College Station, TX, USA, pp. 1-6, <https://doi.org/10.1109/TPEC51183.2021.9384963>.
- [4] A. N. Hussain, W. S. Al-Jubori, and H. Kadom, "Hybrid design of optimal capacitor placement and reconfiguration for performance improvement in a radial distribution system," Journal of Engineering, vol. 2019, pp. 1-15, 2019, <https://doi.org/10.1155/2019/1696347>.
- [5] H. Lotfi, M. Samadi, and A. Dadpour, "Optimal Capacitor Placement and Sizing in Radial Distribution System Using an Improved Particle Swarm Optimization Algorithm," 2016 21st Conference on Electrical Power Distribution Networks Conference (EPDC), Karaj, Iran, 2016, PP. 147-152, <https://doi.org/10.1109/EPDC.2016.7514799>.
- [6] R. Sirjani and B. Hassanpour, "A New Ant Colony-Based Method for Optimal Capacitor Placement and Sizing in Distribution Systems," Research Journal of Applied Sciences, Engineering and Technology, vol. 4, NO. 8, pp. 888-891, April 2012.
- [7] S. Sultana and P. K. Roy, "Optimal capacitor placement in radial distribution systems using teaching learning-based optimization," Electrical Power and Energy Systems, vol. 54, pp. 387-398, January 2014, <https://doi.org/10.1016/j.ijepes.2013.07.011>.
- [8] Essam A. Al-Ammar, Ghazi A. Ghazi, Wonsuk Ko, Yasin Khan, Abderrahmane Beroual, Junhee Hong, Seung-Ho Song, "Comprehensive impact analysis of ambient temperature on multi-objective capacitor placements in a radial distribution system", Ain Shams Engineering Journal, vol.12, no.1, pp.717, 2021, <https://doi.org/10.1016/j.asej.2020.05.003>.
- [9] M. H. M. Jahromi, P. Dehghanian, M. R. M. Khademi, and M. Z. Jahromi, "Reactive Power Compensation and Power Loss Reduction using Optimal Capacitor Placement," 2021 IEEE Texas Power and Energy Conference (TPEC), pp. 1-6, College Station, TX, USA, February 2021, <https://doi.org/10.1109/TPEC51183.2021.9384963>.
- [10] H. F. Kadom, A. N. Hussain, and W. K. S. Al-Jubori, "Optimal dual design based on capacitor placement and reconfiguration techniques for loss reduction and voltage enhancement," The Fourth Scientific Conference for Engineering and Postgraduate Research, Baghdad, Iraq, vol. 745, NO. 1, pp. 1-18, 2019, DOI 10.1088/1757-899X/745/1/012003.
- [11] M. P. Praniha, and K. R. M. V.Chandrakala, "Optimal capacitor placement based improved reliability assessment of a distribution system," 2017 International Conference on Intelligent Computing and Control (I2C2), pp. 1-6, Coimbatore, India, 2017, <https://doi.org/10.1109/I2C2.2017.8321900>.
- [12] D. Issicaba, and J. Coelho, "Rotational Load Flow Method for Radial Distribution Systems," International Journal of Electrical and Computer Engineering (IJECE), vol. 6, NO. 3, pp. 1344 – 1352, June 2016.
- [13] J.A. M. Rupa, and S.Ganesh, "Power flow analysis for radial distribution system using backward/forward sweep method," International Journal of Electrical, Computer, Electronics and Communication Engineering, vol. 8, NO. 10, pp.1540-1544, 2014.
- [14] H. K. Verma and P. Singh, "Optimal reconfiguration of distribution network using modified culture algorithm," Journal of The Institution of Engineers (India): Series B, vol. 99, pp. 613-622, 2018, <https://doi.org/10.1007/s40031-018-0344-6>.
- [15] G. S. Kumar, Dr. S. S. Kumar, and Dr. S. V. J. Kumar, "DG Placement Using Loss Sensitivity Factor Method for Loss Reduction and Reliability Improvement in Distribution System," International Journal of Engineering & Technology, vol. 7, NO 4.22, pp. 236-240, 2018, <https://doi.org/10.1155/2023/1943535>.
- [16] M. Z. Kamaruzaman, N. I. A. Wahab, M. N. M. Nasir, "Reliability Assessment of Power System with Renewable Source using ETAP," International Conference on System Modeling & Advancement in Research Trends (SMART), Moradabad, India, 2018, pp. 236-242, <https://doi.org/10.1109/SYSMART.2018.8746980>.
- [17] S. Cheng, H. Lu, X. Lei, and Y. Shi, "A quarter century of particle swarm optimization," Complex & Intelligent Systems, vol. 4.3, pp. 227-239, April 2018, <https://doi.org/10.1007/s40747-018-0071-2>.
- [18] S. Dutta, and S. P. Singh, "Optimal Rescheduling of Generators for Congestion Management Based on Particle Swarm Optimization," IEEE Transactions on Power Systems, Vol. 23, NO. 4, PP. 1560 – 1569, November 2008, <https://doi.org/10.1109/TPWRS.2008.922647>.
- [19] X. Yuan, H. Nie, A. Su, L. Wang, and Y. Yuan, "An improved binary particle swarm optimization for unit commitment problem," Expert Systems with Applications, vol. 36, NO. 4, pp. 8049-8055, May 2009, <https://doi.org/10.1016/j.eswa.2008.10.047>.
- [20] N. Gupta, A. Swarnkar, and K. R. Niazi, "Distribution network reconfiguration for power quality and reliability improvement using Genetic Algorithms," International Journal of Electrical Power & Energy Systems, vol. 54, pp. 664-671, January 2014, <https://doi.org/10.1016/j.ijepes.2013.08.016>.
- [21] P. Díaz, M. P. Cisneros, E. Cuevas, O. Camarena, F. A. F. Martinez, and A. González, "A Swarm Approach for Improving Voltage Profiles and Reduce Power Loss on Electrical Distribution Networks," IEEE Access, vol. 6, pp. 49498 – 49512, September 2018, <https://doi.org/10.1109/ACCESS.2018.2868814>.
- [22] Y. Mohamed Shuaib, M. Surya Kalavathi, C. Christober Asir Rajan, "Optimal capacitor placement in radial distribution system using Gravitational Search Algorithm," Electrical Power and Energy Systems, vol. 64, pp. 384-397, January 2015, <https://doi.org/10.1016/j.ijepes.2014.07.041>.