



## REVIEW ARTICLE - CONTROL AND AUTOMATION ENGINEERING

### A Survey of Datacenter and Optical Data Center Networks

Esraa Ali Abdulmahdi<sup>1\*</sup>, Ali Al-Askery<sup>1</sup>, Adnan Hussein Ali<sup>2</sup>, Safiye Ghasemi<sup>3</sup>

<sup>1</sup>Electrical Engineering Technical College, Middle Technical University, Baghdad, Iraq

<sup>2</sup>Institute of Technology / Baghdad, Middle Technical University, Baghdad, Iraq

<sup>3</sup>Department of Computer Engineering, Sepidan Branch, Islamic Azad University, Sepidan, Iran

\* Corresponding author E-mail: [bbc0059@mtu.edu.iq](mailto:bbc0059@mtu.edu.iq)

Article Info.	Abstract
<p><i>Article history:</i></p> <p>Received 09 August 2023</p> <p>Accepted 05 January 2024</p> <p>Publishing 30 September 2024</p>	<p>The technology of reconfigurable optical networks (RONs) is growing to be a promising solution to effectively cater to the rapidly increasing traffic generated by the digital society. The present study offers an overview of the datacenter technology and optical datacenter with details of its concepts and technologies. First, the optical data center systems are described and the components that describe it are network operations. Then, we detail the specific technologies that are important to data center networks throughout wide-area networks, analyzing them deeply. Finally, we make a comprehensive between some related works with an analysis of the algorithmic challenges faced by these technologies. In addition, we examine the solutions that have been developed to address these challenges and explore the relevant systems and implementation considerations.</p>
<p>This is an open-access article under the CC BY 4.0 license (<a href="http://creativecommons.org/licenses/by/4.0/">http://creativecommons.org/licenses/by/4.0/</a>)</p>	
<p>Publisher: Middle Technical University</p>	
<p><b>Keywords:</b> Data Center; Optical Switching; Optical Data Center Networks; ODCN; DCNs.</p>	

## 1. Introduction

Data center networks that depend on electrical switching have an inherent constraint in terms of bandwidth capacity. To successfully reduce the increasing traffic demands inside these networks, it is imperative to implement appropriate measures, multi-tier switching layers that are both inefficient and power-intensive are often employed. The exploration of optical switches as a viable alternative to electrical switches in data center networks has been driven by the potential benefits they provide, including ultra-large bandwidth and excellent efficiency in terms of cost and power usage. The optical switch that has a high bandwidth is not affected by the bit-rate or data-format of the transmitted traffic. This is because the optical switch benefits from the optical transparency. In addition, moving the switching operation from the electrical domain to the optical domain eliminates the need for power- and time-intensive optical to electrical– electrical to optical conversions as well as the need for dedicated electronics circuits for several formats of modulation, which results in a significant reduction in both processing delay and the system cost [1, 2]. In addition, the unlimited bandwidth that is made available by the optical switching approaches also enables seamless support for the exploitation of wavelength-division multiplexing technology (WDM), which enables flexible and high-efficiency utilization of the available capacity [3].

Several possible configurations of optical data center networks (ODCNs) are being proposed and analyzed numerically using various optical switch techniques. These techniques include micro-electro-mechanical system (ME-MS) based on Wave-Cube [4], semiconductor optical amplifier (SOA) based HiFOST [5] and OP-Square [6], and LIONS [7]. Additionally, some architectures combine these techniques with wavelength-selective switches, as presented in a previous study. All of the optically switched schemes mentioned above have a fixed optical bandwidth among any top of racks (ToR) once the network has been established. This is because the amount of pre-deployed transceivers (TRXs) determines the bandwidth. This implies that the optical bandwidth is not flexible enough to be dynamically adjusted in response to changes in the volume of DC traffic [8]. However, the provision of fixed bandwidth is inadequate for most data center network (DCN) scenarios. This is not just because of the lower efficiency in network resource usage but also because the unmodifiable bandwidth cannot ensure network performance [9].

The main goal of this survey is to emphasize and classify RONs within enterprise networks. The present discourse provides a succinct overview of the fundamental principles utilized in diverse scenarios by RONs, software-defined networks (SDN), and elastic optical networks (EONs). The present discussion outlines crucial elements that network designers must take into account while constructing a reconfigurable optical network.

Nomenclature & Symbols			
DCN	Data Center Network	QoS	Quality of Service
EON	Elastic Optical Network	RONs	Reconfigurable Optical Networks
HiFOST	Scalable and Low-Latency Hybrid Data Center Network	SDH	Synchronous Digital Hierarchy
IP	Internet Protocol	SDN	Software-Defined Networking
ME-MS	Micro-Electro-Mechanical System	SiPh	Silicon Photonics
NIC	Network Interface Card	SOA	Semiconductor Optical Amplifier
OBS	Optical Burst Switching	SONET	Synchronous Optical Network
ODCN	Optical Data Center Network	ToR	Top-of-Rack
OPS	Optical Packet Switching	TRXs	Pre-Deployed Transceivers
OTN	Optical Transport Network	WDM	Wavelength-Division Multiplexing

## 2. Concepts of Datacenter and ODCNs

A data center refers to a specialized physical infrastructure that is designated for computing, storing, and transmitting significant volumes of traffic data. This facility is typically located within a cluster of buildings and is operated by trained personnel. The design of a data center is founded upon a computing network and its accompanying components, including storage and telecommunications, which facilitate the functioning of the applications and services that are housed within it [1]. Data centers are comprised of various components such as routers, servers, firewalls, switches, application delivery controllers, and storage systems. The design and construction of data centers must prioritize stability due to the crucial role played by the components in processing and storing business-critical data.

DCNs set up and connect all of the network-based equipment and devices in a data center so that they may communicate reliably. So, the DCNs make sure that the nodes inside the facility can talk to each other and share info with users outside the facility [10]. There are two types of existing electrically switched-based DCN architectures: server-centric architectures and switch-centric systems [11]. In server-centric networks, switch nodes are used as cross-connects, along with routing intelligence that should reside on servers with multiple Network Interface Card (NIC) interfaces per server. Switch nodes are used as cross-connects in server-centric networks, and routing information should be put on servers which have more than one NIC port. In switch-centric networks, the routing intelligence is on the switch nodes, and every server generally connects to the network through only one NIC port. The main benefit of switch-centric networks that separate communication and computation is that they are based on tried-and-true technologies for forwarding and routing traffic, such as internet protocol (IP) broadcasting, link-state routing, and equal-cost multipath forwarding [12]. Even though several server-centric designs that take advantage of low-cost switches have been proposed, the most common scheme for DCNs [13] is built on switches. For example, multi-tier tree-like architectures are still the most popular, and the fat-tree and leaf-spine designs are some of the most encouraging in terms of cost, scalability, and reliability. All of these designs are based on switches.

Recent DCNs depending on electrical switches are arranged in a hierarchical topology, that is inhibited by the bandwidth bottleneck in addition to poor power efficiency to provide the needed and higher quality of services [14]. On the other hand, electrical switches represent electrical switches that can double their bandwidth roughly every two years at the same cost based on Moore's law [15]. This makes it possible for data centers to preserve the network bandwidth requirements while keeping a relatively steady and low network cost through the passing years [16]. Even so, the move toward powerful servers and applications of traffic boosting and significantly boosts the network bandwidth demands. Achieving the need for higher network bandwidth certain for the aggregation switch nodes can highly inflate costs. Due to the limited number of high-speed pins available on the switch chip and the limited number of connectors on the front panel of the rack unit, the bandwidth of electrical switches is supposed to hit the bandwidth bottleneck soon [17]. Furthermore, the electrical switches consume power proportional to the data rate, as the switch dissipates energy with every bit transition [18]. With the speed scaling-up requirements, the electrical switches-based DCNs face stringent pressures on power consumption. Despite the presence of new technologies depending on Silicon Photonics (SiPh), monolithic integration and multi-tier packaging have been investigated; several challenges, however, still need to be resolved before these solutions become practicable [19, 20]. For example, the high manufacturing (which includes both testing and packaging) costs, there are some challenges including the packaging complexity with a large number of external laser sources and fiber coupling. Even when these issues are capable of being resolved, these techniques will ultimately be difficult to maintain, raising the transistor density restricted by the CMOS scaling [21].

Thus, to address the bandwidth limitations of electrical switches, an optical switching technique has garnered significant interest among researchers to be a viable solution that ensures long-term viability. The independence of bit-rate as well as data format of traffic is a result of optical transparency when switching data in the optical domain [22]. Optical switching can provide significantly greater bandwidth than electrical switching while also achieving lower packet completion times. This is due to the elimination of electronic circuits for the switching. Furthermore, the utilization of the WDM technique has the potential to enhance the capacity of optical networks while achieving the performance of premium power-per-units [23]. Optical switching, when combined with WDM, presents a feasible approach to address the count limitation issue associated with high-speed pins with front panel connectors in electrical switches [24]. In addition, it is noteworthy that the utilization of optical switches obviates the need for power-intensive electro-optical and opto-electrical conversions, thereby resulting in a marked reduction in the quantity of costly and energy-intensive transceivers. The aforementioned advantages can be leveraged to achieve a flattened network topology, thereby circumventing the scalability limitations of the hierarchical topology of data centers [25].

## 3. Optical Switching Techniques

To date, four principal optical switching techniques have been studied, increasing the data transfer capabilities of data center networks which are:

### 3.1. Optical circuit switching

Since the early 2000s, optical circuit switching has been considered to be the basic technology underlying backbone networks. Optical circuit switching utilizes a static allocation of a light-path connection that spans from end to end [26]. The mapping of the connection is allocated to one or multiple wavelengths that are exclusively assigned to the connection. Optical circuits can traverse nodes referred to as reconfigurable optical add-drop or optical cross-connects multiplexers in a "transparent" manner. This implies that there is no need for expensive and energy-intensive conversions between the optical and electrical domains, nor is there any processing in the electrical domain, like electronic switching [27]. In general, optical circuit switching networks are designed to accommodate the maximum demand for every connection [28]. This approach is effective and minimizes capacity wastage in situations where demands remain relatively stable over time, such as in backbone networks in which multiple demands are aggregated. Moreover, optical circuit switching is afflicted by the N<sup>2</sup> scalability problem. Specifically, in a network comprising N nodes with densely interconnected demands, where nearly all nodes necessitate communication with almost all other nodes, the number of circuits needed increases exponentially as N<sup>2</sup>. This exponential growth can rapidly deplete the finite number of wavelengths (usually ranging from 80 to 96) that are accessible in the C-band transmission upon an optical fiber. optical circuit switching networks exhibit a static behavior and are not intended to undergo reconfiguration at a timescale faster than that of seconds or milliseconds. In practice, their reconfiguration is usually carried out at significantly slower rates [29].

### 3.2. Optical packet switching

The optical packet switching (OPS) concept is currently gaining traction as a viable substitute for the more granular switching methods in the optical realm. Notwithstanding the noteworthy technological obstacles that it encounters, OPS exhibits the potential of a greatly adaptable, data transmission-efficient, and adaptable optical stratum [30, 31]. 'All' and 'almost-all' optical switching are two subcategories of optical packet switching. The data channel is entirely optical in both types; however, the control functionality varies. In "almost-all" optical networks, switching operation control is handled electronically, whereas switching operation control is anticipated to be entirely optical or optoelectronic in "all" optical networks. There are two further categories of optical packet switching: (1) photonic packet switching [32] and (2) optical burst switching [33]. The photonic packet switching integrates high-capacity optical communication with fine granularity and efficient packet switching multiplexing. With the wide bandwidth of photonic components, the adaptability of wavelength-division multiplexing along with wavelength routing techniques, in addition the high-speed ability of optical devices, it is possible to construct networks-based packet-switched with throughputs in the terabit-per-second range. The technology known as optical packet switching suffers from problems with both the cost and its technology. The most significant of these problems is that there is no optical buffer memory with random access available [34]. An additional method known as optical burst switching (OBS) is solution-based optical networking that can give the benefits of OPS while eliminating the optical buffer memory as well as other obstacles [35]. OBS is a compromise between circuit switching and packet switching. To save bandwidth resources to serve as a 'burst circuit' before the arrival of every data burst over the data wavelength, hence, OBS [8] delivers control packets that travel on divided wavelengths ahead of each data burst of variable length. This occurs before each data burst arrives on a wavelength of data. The resources will become available once the burst has concluded. In terms of functionality, this kind of instantaneous circuit switching eliminates the requirement along the line for buffer memory to deal with the traffic bursts. In addition, the criteria for synchronization in OBS are laxer than those in OPS because there is less of a tight link between the control signals and the data. In conclusion, because control packets are far less extensive than data payloads, one or two control wavelengths are capable of supporting a considerable number of data wavelengths [36, 37].

### 3.3. Optical transport network (OTN)

Recent developments in transport technology, such as the optical transport network (OTN), have made it possible for optical communications switching networks to support sub-wavelength switching. Statistical multiplexing can be accomplished with OTN by using a single transponder to deliver data to several TDM destinations. This is made possible by the use of a single transponder. At intermediate nodes, in a manner analogous to that of conventional electronic switching, Optical transport signals can be regroomed within the electrical domain to have to improve the packing for the data across the optical fibre. This is done to maximize the amount of information that can be carried by the optical fiber. In the same way as electronic packet switching does, this breaks the optical transparency model for the traffic that has been groomed and necessitates the use of a dedicated switching fabric. Because switching within the optical domain in OTN is accomplished with the same slowly reconfigurable switching fabric that is used in optical communications switching, this results in the OTN network having a lower degree of dynamic capability when compared to the network-based electronic packet-switching. For example, the A–E demand travels undetected through the node [38]. Table 1 shows a comparison between optical switching technology.

Table 1. Comparison between optical switching technology

Optical Switching Technology	Characteristics					
	Control Overhead	Bandwidth Utilization	Flow Completion Delay	Complexity	Switching Granularity	Applicability
Optical circuit switching	low	low	high	low	coarse	medium
Optical packet/slot switching	high	high	low	high	fine	high
Optical transport network	low	medium	medium	medium	medium	

## 4. RONS Architectures

There exist two different types of network architecture that have the potential to utilize reconfigurable optics, one is IP-over-OTN and the second is hybrid electric-ODCNs Networks.

### 4.1. IP-over-RONS

The traditional transport network faces challenges in providing high bandwidth and optimizing bandwidth efficiency, which can result in a bottleneck. Hence, it is imperative to achieve the convergence of IP and optical networks. The IP layer is primarily responsible for performing

precise traffic routing and grooming, whereas the optical layer is accountable for furnishing transmission channels that are characterized by low latency, high capacity, and long-haul capabilities [39]. The implementation of a bandwidth-on-demand application can be achieved through the intelligent management of traffic demands along with the integration of IP and optical technologies. This approach shows great potential in enhancing network capacity, reliability, and service deployment. The integration of IP techniques and optical networks with large-capacity techniques through IP over optical network technology facilitates the entry of IP data streams into the optical channel. This convergence presents advantageous prospects for the improvement of optical networks that cater to data services. An IP network is a type of network that utilizes the TCP/IP protocol as its primary protocol of communication. The Internet is considered the most exemplary form of IP network among the various types available. Traditional optical network bearers include circuit switches and IP packet services that rely on optical transport networks or synchronous digital hierarchy (SDH) / synchronous optical network (SONET). The proliferation of the Internet has led to the emergence and rapid development of several high-bandwidth, real-time services. Consequently, the bandwidth resources of current IP networks are experiencing a surge in demand. The optical network has undergone a series of advancements, including WDM, SDH, multiservice transport platform, and packet division, in response to the constant emergence of novel services. The evolution of the transport network has progressed from the adoption of the automated switched optical network for more recent EON [40]. Simultaneously, it is imperative for optical network hardware, including transponders and switches, to possess the capability of software programmability [41]. Additionally, the integration of the control circuit for a chip has become a crucial aspect. Evolutionarily speaking, optical networks are expected to progress towards the integration of multi-dimensional, large-capacity, intelligent features, flexible and dynamic. The proliferation of IP services, coupled with the swift advancement of high-speed router techniques and the widespread implementation of optical network bearer techniques, has brought about significant transformations in the design of forthcoming networks [42].

#### 4.2. Data center architecture in RONS

In the past, data centers have predominantly utilized packet-switched networks to interconnect their servers. Nevertheless, with the escalation of scale and demand, the expenses associated with constructing and administering these networks have grown excessively high. The alteration in question has led to an increased focus by both researchers and major cloud service providers on novel network topologies that are capable of being reconfigured. Over the past decade, a multitude of novel data center architectures featuring reconfigurable optical methods have been proposed. These architectural designs share the characteristic of minimizing the static provisioning demands of the network, resulting in cost reduction by enabling periodic alterations in the bandwidth between hosts [43]. The hybrid electrical-optical data center architecture is exemplified in Fig. 1.

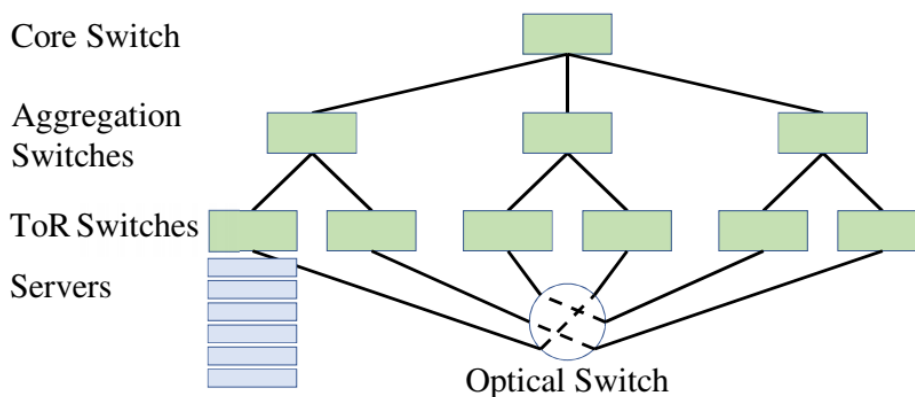

Fig. 1. Data center architecture [43]

The aforementioned architectures employ scheduling techniques to modulate the bandwidth of optical paths within the data center, thereby mitigating both cost and complexity. Several methodologies have been exhibited. Prominent architectural designs utilize either deterministic and fixed scheduling methodologies [44, 45], or demand-aware modifications that give priority to implementing optical paths between servers that have mutual connectivity requests. The diversity of switching fabrics is also applicable to optical systems in data centers. Various types of fabrics have been developed for optical applications, such as those based on digital micromirror devices [46], nanosecond tunable lasers [47], and liquid crystal over silicon wavelength-selected switches [48].

As described in [49], the architecture of the reconfigurable OP-Square DCN is explained in Fig. 2(a). Electrical ToR switches connect the H-servers in each rack to one another, and the M racks that make up a cluster are clustered together. The DCN that has been proposed contains N different clusters. The traffic that is generated by the servers may be divided into three types: intra-ToR traffic, intra-cluster traffic, and inter-cluster traffic. The ToRs will be responsible for handling all of this traffic. Communication within a cluster is handled by the N MM intra-cluster optical switches, while communication between clusters is handled by the M NN inter-cluster optical switches (ES). The i-th ToR in each cluster is connected to the other ToRs in the cluster via the i-th ES (1iN). P and q WDM transceivers with specific electronic buffers are used to join the IS with the ToR and ES, respectively, to facilitate the transmission of inter-cluster and intra-cluster traffic, respectively. It is possible to elastically allocate the amounts of p and q on demand by the intended capacity, the level of oversubscription, and the ratio of intra-cluster traffic to inter-cluster traffic.

In Fig. 2(b), the ToR function blocks are depicted for reference. The head processor is the initial component that deals with the incoming packets, which might have a variety of lengths and destinations. When the packet is part of the intra-ToR communication, it will be routed to the port that links to the target server within the same rack and buffered there. In the case of intra/inter-cluster links, the packets will be sent to the ports that are connected with the inter-cluster TXs (q) or intra-cluster TXs (p), respectively. It is possible to adjust the quantities of p and q that are used to connect the ToR to both the intra - and inter-cluster networks. To adjust the wavelengths (and consequently the bandwidth per link) to IS and ES, a wavelength-selective switch is utilized [49].

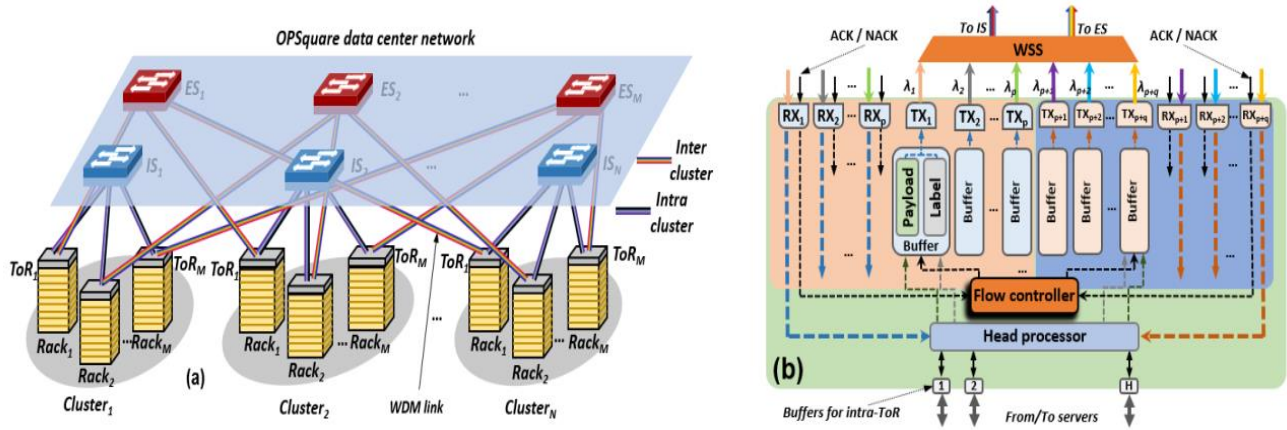

Fig. 2. (a) Data center network design that is reconfigurable and based on OPSquare; (b) ToR function block [49]

In Fig. 3, you can see the optical switch that has a modular structure. Every modular contains both p and q wavelengths. When the payload is being fed to the broadcast and choose 1×N switch, the label extractor will separate the optical label from its payload and then perform processing on it in real-time. With the label bits that were recovered, the controller of the 1N switch enables the SOA gates so that the packets can be sent. The combiner gathers together light of the same wavelength that is headed in the same direction. The contention issue is resolved by the switch controller, which then controls the 1N switch appropriately. It is important to take note that there was only room for one wavelength to travel through the combiner at any given period. The controller is responsible for producing flow control signals known as ACK and NACK, which are then relayed back to ToR to either release the electrical buffers or seek retransmission [49].

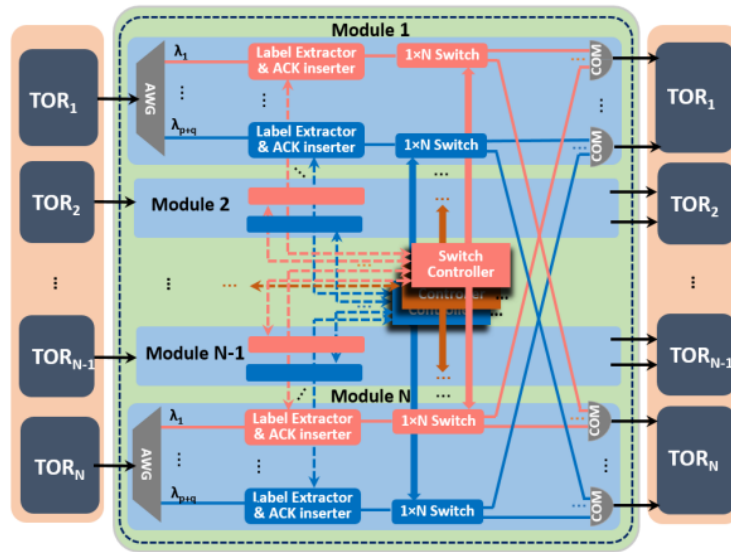

Fig. 3. The optical switch that has a modular structure

#### 4.3. Elastic optical networks

The transmission of data over a range or series of wavelengths is facilitated by a length of optical fiber. The allocation of these wavelengths can be done either in a fixed or flexible grid. Elastic optical networks, often known as EONs, are another name for networks that support flexible grid allocations. Flex grid networks have the potential to significantly enhance the spectral efficiency of IP-over-OTN. This would make it possible for the network to load more data channels into the same length of optical fiber. On the other hand, they can also bring forth one-of-a-kind difficulties, most notably fragmentation. A spectrum that has been assigned on a cable may experience fragmentation if the spectrum contains gaps that are too narrow to be filled [50].

There are several researches to study and improve RONS, in [51], a novel approach to DCN fabric that utilizes the reconfigurability of optical transceivers and switches. This approach enables the dynamic adjustment of end-to-end optical routes to accommodate fluctuating traffic demands. The result is an all-optical DCN fabric that offers superior performance and flexibility. The problem of dynamic flow scheduling in conjunction with wavelength assignment has been determined to be NP-hard. The work involves the implementation of centralized heuristics to facilitate inter-rack flow scheduling. This will be achieved through the utilization of optical wavelength division multiplexing, with a focus on minimizing the variety of intermediate optical hops. The results of the study demonstrate that the suggested framework and scheduling of data flow effectively mitigate network congestion by a significant margin of 1518 times in comparison to existing part-time ODCNs. This conclusion is based on comprehensive simulations conducted during this research. The proposed scheme can achieve a delivery rate of over 90% for inter-rack traffic by using direct optical communication in the majority of traffic patterns. In [52], the researchers introduce a novel reconfigurable architecture named RODCA, which exhibits both scalability and flexibility. The RODCA system is constructed based on the PODCA-L architecture and enhances it by incorporating a versatile optical network within the cluster. The utilization of a reconfigurable intra-



cluster network allows for the co-location of racks that experience high levels of traffic within a given cluster. This arrangement enables the sharing of the substantial bandwidth provided by the intra-cluster network. The authors introduce an algorithm designed to reconfigure DCN topology. Additionally, simulation results are provided to showcase the efficacy of the reconfiguration process. The findings indicate that by implementing strategic topology reconfiguration in response to fluctuations in traffic, it is possible to achieve packet latencies of approximately 10-12  $\mu$ s. Conversely, if topology reconfiguration is not employed, latencies may increase by a factor of ten. Sans (2019)[53] was demonstrating experimentally the programmable OPsquare datacentre network enabled by an SDN control plane. The implementation is based on monitoring the network's real-time statistics so that network slice reconfiguration and provisioning, assignment of packet priority class, and dynamic load balancing operations can be performed to attain the required Quality of Service level. Abu-Tair et al. (2019) [54], developed a reconfigurable optical data centre networks model employing SDN controlled that simulates the behavior of such networks, while ensuring that the overall capacity remains constant. This approach allows for a better understanding of system behavior. This paper presents an investigation study, highlighting the potential negative effects of network reconfiguration on the performance of Transmission Control Protocol (TCP) congestion control methods. These results show that the reconfigurations can significantly impair system performance. In addition, they study several strategies, and the results indicate that an on-demand scheduling mechanism has the potential to enhance throughput by over 50% without requiring any more network capacity. Hence, these results suggest the necessity of establishing a connection between network resource management and emerging datacenter network architectures. In depth analysis of a revolutionary DCN has been achieved by [55], to investigate the capability of DCN to meet the high capacity and low latency needs of contemporary cloud computing applications. This adaptable architecture, which is known as AgileDCN, makes use of fast-switching optical components and combines them with a centralized control mechanism and workload scheduler. Even with uneven loading patterns, it is possible to achieve very high network efficiency through the provision of a highly flexible optical network fabric that is connected between server racks. According to the results of their simulations, the TCP flow completion times within the AgileDCN are noticeably quicker than those in an analogous electronic leaf-spine network even when the load is rather high (70%). An experimental evaluation of a reconfigurable ODCN has been achieved by [56] that is enabled by software-defined networking and features dynamic bandwidth allocation. Their approach is founded on innovative optical top-of-rack architectures that utilize a wavelength-selective switch. Empirical evaluations demonstrate that the suggested approach can dynamically reassign the optical bandwidth in real-time to accommodate the changing traffic patterns. In contrast to the traditional ODCN that employs static bandwidth allocation, the reconfigurable approach with flexible bandwidth allocation demonstrates a 58.3% enhancement in end-to-end latency performance and a reduction of one order of magnitude in average packet loss. Furthermore, the reconfigurable ODCN exhibits deterministic latency performance, characterized by significantly reduced packet delivery completion time variations. The simulation platform has been constructed to verify the strong scalability of the reconfigurable DCN, by the experimental parameters. The numerical findings demonstrate a minimal decline in performance (11%) when the network expands from 2560 to 40,960 servers. In [57], a novel model called (RGAIA) has been designed along with empirical analysis of a reconfigurable optical packet switching DCN. The network utilizes flexible top-of-rack (ToR) architecture and a high-speed optical switch, which is realized through a tunable transceiver combined with an arrayed waveguide grating router. RGAIA can dynamically allocate wavelength resources and reconfigure bandwidth in real-time, depending on monitored traffic features, under the control of the developed SDN control plane. Empirical evaluations confirm that RGAIA enhances network performance by 66% and 37% in terms of packet loss and latency, consequently, as compared to a network with inflexible interconnections, when subjected to a traffic load of 0.8. A novel control system and optical switching for ODCNs has been achieved by [1] that leverages the label control method, clock distribution, and OFC protocol to achieve nanosecond data recovery. The system was experimentally demonstrated and validated. The optical label channels are responsible for delivering the designated time, label signals for forwarding OFC protocol signals, and nanosecond packets for resolving packet contention. The experimental findings validate an optical switching and control system that operates at an average speed of 43.4 ns. The system also exhibits a data recovery time of 3.1 ns without binary code decimal representation receivers. Furthermore, the system maintains a loss rate of packet of less than  $3 \times 10^{-10}$  over ten days of stable and continuous network operation. The results show that the implementation of ODCN architectures that offer higher capacity and low latency. Xue et al. (2022) [58] proposed an experimental evaluation of a reconfigurable optical DCN with dynamic bandwidth allocation, leveraging SDN technology. The proposed approach utilizes innovative optical top-of-rack (ToR) devices that incorporate a wavelength-selective switch (WSS). Empirical evaluations demonstrate that the suggested approach possesses the capability to autonomously reassign the optical bandwidth promptly, hence accommodating the ever-changing traffic patterns. In contrast to the traditional optical data center network (DCN) that employs static bandwidth provisioning, the reconfigurable method with adaptable bandwidth allocation demonstrates a significant enhancement in end-to-end latency performance, with an improvement of 58.3%. Additionally, this scheme exhibits a substantial reduction in average packet loss, decreasing by one order of magnitude. Additionally, the reconfigurable optical data center network (DCN) exhibits deterministic latency performance, characterized by significantly reduced temporal fluctuations in the completion of packet delivery. The simulation platform is constructed to verify the strong scalability of the proposed reconfigurable DCN by the experimental conditions. The numerical findings demonstrate a minimal decline in performance (11%) as the network expands from 2560 to 40,960 servers. These architectures rely on nanosecond-distributed optical switches and a nanosecond control system. For ODCN which is enabled by SDN, [59] proposed a network that is experimentally evaluated with a focus on its ability to provide flexible quality of service (QoS) for multi-tenant applications that are deployed within the network. The ODCN that is enabled by SDN proposes an approach whereby the network topology and statistics are monitored to facilitate automatic slicing and reconfiguration. The SDN controller is responsible for managing this process. The experimental findings confirm that the implementation of a flexible priority allocation scheme for NS traffic flows can effectively deliver dynamic QoS. Furthermore, the automated implementation of load balancing, which is predicated on the analysis of network statistics, serves to enhance network performance by ensuring a high quality of service. The NS with the highest priority has exhibited zero packet loss and an end-to-end latency of less than 4.8 seconds at a load of 0.5. Chen et al. (2023) [60], proposed a technique for building a user-defined network topology with a few common switches named a Software Defined Topology Testbed (SDT). The software-defined testbed (SDT). It is cost-effective, easily deployable, and offers reconfigurability. This allows for the execution of various experiments using alternative network topologies. By employing distinct topology configuration files in the developed controller, several sets of experiments can be conducted. A prototype of the Self-Directed Training (SDT) model is developed, and a series of experiments are conducted. The evaluations indicate that the use of SDT results in a maximum additional overhead of 2% compared to full testbeds in terms of multi-hop latency. Furthermore, SDT demonstrates significantly higher efficiency compared to software simulators, lowering the evaluation time by up to 2899 times. The cost-effectiveness and scalability of SDT surpass that of current Topology Projection (TP) methods. Additional studies demonstrate that SDT can facilitate a wide range of network research experiments with minimal financial investment. These experiments encompass a broad spectrum of issues, such as topology design, congestion control, and traffic engineering, among others. Table 2 summarises and compares the studies in the field of RONS.

Table 2. Comparison between some recent studies for RONS

Study Ref.	Year	Model	Achievement
Pal and Kant[51]	2015	DCN fabric that utilizes the reconfigurability of optical transceivers and switches to enable the dynamic adjustment of end-to-end optical routes to accommodate fluctuating traffic demands.	The model achieves a delivery rate of over 90% for inter-rack traffic by using direct optical communication in the majority of traffic patterns.
Liu et al. [52]	2019	A novel reconfigurable architecture named RODCA which constructed based on the PODCA-L architecture and enhances it by incorporating a versatile optical network within the cluster	Achieve packet latencies of approximately 10-12 $\mu$ s
Sans [53]	2019	The present study addresses the advantages associated with the utilization of an OPSquare architecture that relies on rapid optical switches, specifically Semiconductor Optical Amplifiers (SOA), in conjunction with optical flow control.	To get the desired Quality of Service level, several actions can be undertaken, such as the provisioning and reconfiguration of network slices, the assignment of packet priority classes, and the implementation of dynamic load balancing procedures.
Abu-Tair et al. [54]	2019	Developed a network model that simulates the behavior of optical data center networks using reconfigurable	These results show that the reconfigurations can significantly impair system performance. In addition, they study several strategies, and the results indicate that an on-demand scheduling mechanism has the potential to enhance throughput by over 50% without requiring any more network capacity. Hence, these findings suggest the necessity of establishing a connection between network resource management and emerging datacenter network architectures.
Le et al. [55]	2020	Simulation's analysis of DCN that is capable of meeting the high capacity and low latency needs of contemporary cloud computing applications	TCP flow completion times within the AgileDCN are noticeably quicker than those in an analogous electronic leaf-spine network even when the load is rather high (70%).
Xue et al.[56]	2021	Experimentally presented and evaluated a reconfigurable ODCN that is enabled by software-defined networking and features dynamic bandwidth allocation.	Achieve 58.3% enhancement in end-to-end latency efficiency and minimization of one order of magnitude in average packet loss. A minimal decline in performance (11%) when the network expands from 2560 to 40,960 servers.
Che et al. [57]	2022	Design and analysis of a reconfigurable optical packets switching DCN called RGAIA that utilizes flexible ToR architecture and a high-speed optical switch	RGAIA enhances network performance by 37% for latency and 66% for packet loss.
Xue et al. [58]	2022	In this study, a reconfigurable optical data center network (DCN) with dynamic bandwidth allocation was assessed using SDN technology. The evaluation involved the utilization of the optical top of racks, which incorporated a wavelength-selective switch for enhanced performance.	There is a significant enhancement in end-to-end latency performance, with an improvement of 58.3%. Additionally, this scheme exhibits a substantial reduction in average packet loss, decreasing by one order of magnitude. Additionally, the reconfigurable optical DCN exhibits deterministic latency performance, characterized by significantly reduced temporal fluctuations in the completion of packet delivery. The simulation platform is constructed to verify the strong scalability of the proposed reconfigurable DCN by the experimental conditions. The numerical findings demonstrate a minimal decline in performance (11%) as the network expands from 2560 to 40,960 servers
Xue and Calabretta[1]	2022	Proposed a novel optical switching and control system for ODCNs that leverages the label control mechanism, OFC protocol, and clock distribution to facilitate nanosecond data recovery	The results show that the model achieves high capacity and low latency with optical switching and the control system operates at an average speed of 43.4 ns and time for data recovery of 3.1 ns without binary code decimal representation receivers. The packet loss rate is less than $3 \times 10^{-10}$ over ten days of stable and continuous network operation.
Chen et al. [60]	2023	The suggested Software Defined Topology Testbed (SDT) has been developed to enable the construction of user-defined network topology with a limited number of readily available commodity switches.	The evaluations indicate that the use of SDT results in a maximum additional overhead of 2% compared to full testbeds in terms of multi-hop latency. Furthermore, SDT demonstrates significantly higher efficiency compared to software simulators, lowering the evaluation time by up to 2899 times. The cost-effectiveness and scalability of SDT surpass that of current Topology Projection (TP) methods. Additional studies demonstrate that SDT can facilitate a wide range of network research experiments with minimal financial investment. These experiments encompass a broad spectrum of issues, such as topology design, congestion control, and traffic engineering, among others

## Continue Table 2

Lin[59]	2023	An ODCN that is enabled by SDN	The results above that the implementation of a flexible priority allocation scheme for NS traffic flows can effectively deliver dynamic QoS. The NS with the highest priority has exhibited zero packet loss and an end-to-end latency of less than 4.8 seconds at a load of 0.5
---------	------	--------------------------------	--

## 5. Conclusion

The technology of RONS is relatively new, and there is currently limited understanding of both their capabilities and limitations. The focus of this paper is on the analysis of data centers as well as wide-area networks. Numerous other networks could potentially derive advantages from comparable technologies. Furthermore, even within our context, the compromises between expenses and advantages, such as resilience, performance, and efficiency, remain inadequately comprehended. The tradeoffs mentioned are contingent upon the particular technology employed, such as the duration of reconfiguration and the traffic pattern. For instance, reconfigurable networks that are responsive to demand may only be advantageous if the traffic pattern displays temporal and spatial structure. At present, there is a dearth of models about the expenses incurred during the process of reconfiguration. It is noteworthy that these expenses are contingent upon the control plane, thereby presenting another research challenge that remains unresolved. The superiority of decentralized control planes over centralized ones, or the necessity of hybrid designs, remains unclear. The optimal design of control planes remains unclear. RONS pose a largely unexplored complexity terrain from an algorithmic perspective. While traditional networking issues can heavily depend on optimization and graph theory that has been developed over several decades, reconfiguration introduces novel and distinct complexities to networking problems. Therefore, it is our aspiration that our survey will provide a contextual framework for the novel concepts, technologies, and obstacles associated with RONS. Consequently, we aim to facilitate the initiation and advancement of research endeavors in this burgeoning field.

## Acknowledgment

I would like to thank the dean of the Electrical Engineering Technical College for their support and facilities, which enabled us to apply our experiment. In addition, thanks are due to the Department of Computer Technical Engineering for their help and encouragement in finishing our research.

## References

- [1] X. Xue and N. Calabretta, "Nanosecond optical switching and control system for data center networks," *Nature Communications* 2022 13:1, vol. 13, no. 1, pp. 1–8, Apr. 2022, doi: 10.1038/s41467-022-29913-1.
- [2] T. H. Thabit, H. S. Ishhadat, and O. T. Abdulrahman, "Applying Data Governance Based on COBIT2019 Framework to Achieve Sustainable Development Goals," *JT*, vol. 2, no. 3, pp. 9–18, Sep. 2020, <https://doi.org/10.51173/jt.v2i3.212>.
- [3] Jia, Hao, Shanglin Yang, Ting Zhou, Sizhu Shao, Xin Fu, Lei Zhang, and Lin Yang. "WDM-compatible multimode optical switching system-on-chip." *Nanophotonics* 8, no. 5, 889–898, 2019, <https://doi.org/10.1515/nanoph-2019-0005>.
- [4] X. Wang, H. Gu, K. Wang, X. Yu, and S. Ma, "MNMD: MEMS-based N-dimensional modular hybrid data center network," *Opt Commun*, vol. 427, pp. 163–169, Nov. 2018, doi: 10.1016/J.OPTCOM.2018.06.031.
- [5] Yan, Fulong, Xuwei Xue, and Nicola Calabretta. "HiFOST: A scalable and low-latency hybrid data center network architecture based on flow-controlled fast optical switches." *Journal of Optical Communications and Networking* 10, no. 7, 1–14, 2018, <https://doi.org/10.1364/JOCN.10.0000B1>.
- [6] X. Xue et al., "SDN-Controlled and Orchestrated OPSquare DCN Enabling Automatic Network Slicing with Differentiated QoS Provisioning," *Journal of Lightwave Technology*, vol. 38, no. 6, pp. 1103–1112, Mar. 2020, doi: 10.1109/JLT.2020.2965640.
- [7] Y. Yin, R. Proietti, X. Ye, C. J. Nitta, V. Akella, and S. J. B. Yoo, "LIONS: An AWGR-based low-latency optical switch for high-performance computing and data centers," *IEEE Journal on Selected Topics in Quantum Electronics*, vol. 19, no. 2, 2013, doi: 10.1109/JSTQE.2012.2209174.
- [8] K. Prifti et al., "SDN enabled flexible optical data center network with dynamic bandwidth allocation based on photonic integrated wavelength selective switch," *Optics Express*, Vol. 28, Issue 6, pp. 8949–8958, vol. 28, no. 6, pp. 8949–8958, Mar. 2020, doi: 10.1364/OE.388759.
- [9] M. Taubenblatt, P. Maniotis, and A. Tantawi, "Optics enabled networks and architectures for data center cost and power efficiency [Invited]," *Journal of Optical Communications and Networking*, Vol. 14, Issue 1, pp. A41–A49, vol. 14, no. 1, pp. A41–A49, Jan. 2022, doi: 10.1364/JOCN.440205.
- [10] T. Wang, Z. Su, Y. Xia, and M. Hamdi, "Rethinking the data center networking: Architecture, network protocols, and resource sharing," *IEEE Access*, vol. 2, pp. 1481–1496, 2014, doi: 10.1109/ACCESS.2014.2383439.
- [11] D. Li, J. Wu, Z. Liu, and F. Zhang, "Dual-centric data center network architectures," *Proceedings of the International Conference on Parallel Processing*, vol. 2015-December, pp. 679–688, Dec. 2015, doi: 10.1109/ICPP.2015.77.
- [12] G. Qu, Z. Fang, J. Zhang, and S. Q. Zheng, "Switch-centric data center network structures based on hypergraphs and combinatorial block designs," *IEEE Transactions on Parallel and Distributed Systems*, vol. 26, no. 4, pp. 1154–1164, Apr. 2015, doi: 10.1109/TPDS.2014.2318697.
- [13] S. Zafar, A. Bashir, and S. A. Chaudhry, "On implementation of DCTCP on three-tier and fat-tree data center network topologies," *Springerplus*, vol. 5, no. 1, pp. 1–18, Dec. 2016, doi: 10.1186/S40064-016-2454-4/FIGURES/8.
- [14] K. Wu, J. Xiao, and L. M. Ni, "Rethinking the architecture design of data center networks," *Front Comput Sci China*, vol. 6, no. 5, pp. 596–603, Sep. 2012, doi: 10.1007/S11704-012-1155-6/METRICS.
- [15] A. Singh et al., "Jupiter Rising: A Decade of Clos Topologies and Centralized Control in Google's Datacenter Network," *ACM SIGCOMM Computer Communication Review*, vol. 45, no. 5, 2015, doi: 10.1145/2829988.



- [16] J. Zhang, F. R. Yu, S. Wang, T. Huang, Z. Liu, and Y. Liu, "Load balancing in data center networks: A survey," *IEEE Communications Surveys and Tutorials*, vol. 20, no. 3, pp. 2324–2325, Jul. 2018, doi: 10.1109/COMST.2018.2816042.
- [17] H. J. S. Dorren, E. H. M. Wittebol, R. De Kluijver, G. Guelbenzu De Villota, P. Duan, and O. Raz, "Challenges for optically enabled high-radix switches for data center networks," *Journal of Lightwave Technology*, vol. 33, no. 5, pp. 1117–1125, Mar. 2015, doi: 10.1109/JLT.2015.2391301.
- [18] Zhang, Ruihuan, Yu He, Yong Zhang, Shaohua An, Qingming Zhu, Xingfeng Li, and Yikai Su. "Ultracompact and low-power-consumption silicon thermo-optic switch for high-speed data." *Nanophotonics* 10, no. 2, 937-945, 2020, <https://doi.org/10.1515/nanoph-2020-0496>.
- [19] S. Rumley et al., "Optical interconnects for extreme scale computing systems," *Parallel Comput*, vol. 64, pp. 65–80, May 2017, doi: 10.1016/J.PARCO.2017.02.001.
- [20] S. Fatholouloumi et al., "1.6 Tbps Silicon Photonics Integrated Circuit and 800 Gbps Photonic Engine for Switch Co-Packaging Demonstration," *Journal of Lightwave Technology*, vol. 39, no. 4, pp. 1155–1161, Feb. 2021, doi: 10.1109/JLT.2020.3039218.
- [21] S. Manipatruni, D. E. Nikonov, and I. A. Young, "Beyond CMOS computing with spin and polarization," *Nature Physics* 14:4, vol. 14, no. 4, pp. 338–343, Apr. 2018, doi: 10.1038/s41567-018-0101-4.
- [22] N. Calabretta and X. Xue, "Switch Control," *Optical Switching: Device Technology and Applications in Networks*, pp. 257–275, Jul. 2022, doi: 10.1002/9781119819264.CH14.
- [23] X. Fu, J. Ding, T. Zhou, L. Zhang, L. Yang, and H. Jia, "Optical switch compatible with wavelength division multiplexing and mode division multiplexing for photonic networks-on-chip," *Optics Express*, Vol. 25, Issue 17, pp. 20698-20707, vol. 25, no. 17, pp. 20698–20707, Aug. 2017, doi: 10.1364/OE.25.020698.
- [24] D. M. Marom and M. Blau, "Switching solutions for WDM-SDM optical networks," *IEEE Communications Magazine*, vol. 53, no. 2, pp. 60–68, 2015, doi: 10.1109/MCOM.2015.7045392.
- [25] R. Soref and Q. Xu, "Reconfigurable optical directed-logic circuits using microresonator-based optical switches," *Optics Express*, Vol. 19, Issue 6, pp. 5244–5259, vol. 19, no. 6, pp. 5244–5259, Mar. 2011, doi: 10.1364/OE.19.005244.
- [26] C. Develder et al., "Optical networks for grid and cloud computing applications," *Proceedings of the IEEE*, vol. 100, no. 5, pp. 1149–1167, 2012, doi: 10.1109/JPROC.2011.2179629.
- [27] Muhammad, Ajmal. "Planning and provisioning strategies for optical core networks." PhD diss., Linköping University Electronic Press, 2015].
- [28] Smyth, Frank. "Investigation of performance issues affecting optical circuit and packet switched WDM networks." PhD diss., Dublin City University, 2009.
- [29] K. J. Barker et al., "On the feasibility of optical circuit switching for high performance computing systems," *Proceedings of the International Conference on Supercomputing*, vol. 2005-November, 2005, doi: 10.1109/SC.2005.48.
- [30] S. Waheed, "Comparing Optical Packet Switching And Optical Burst Switching," *Daffodil International University Journal of Science and Technology*, vol. 6, no. 2, pp. 22–32, Jan. 2011, doi: 10.3329/DIUJST.V6I2.9342.
- [31] G. N. Rouskas and L. Xu, "Optical packet switching," *Emerging Optical Network Technologies: Architectures, Protocols and Performance*, pp. 111–127, 2005, doi: 10.1007/0-387-22584-6\_5/COVER.
- [32] Yamanaka, Naoaki, ed. *High-Performance Backbone Network Technology*. CRC Press, 2020.
- [33] M. Zahid Hasan, K. M. Zubair Hasan, and A. Sattar, "Burst Header Packet Flood Detection in Optical Burst Switching Network Using Deep Learning Model," *Procedia Comput Sci*, vol. 143, pp. 970–977, Jan. 2018, doi: 10.1016/J.PROCS.2018.10.337.
- [34] Singh, Arunendra, and Amod Kumar Tiwari. "Analysis of hybrid buffer based optical data center switch." *Journal of Optical Communications* 42, no. 3, 415-424, 2021, <https://doi.org/10.1515/joc-2018-0121>.
- [35] M. J. Sadiq, M. J. Zaiter, and R. F. Chisab, "Energy Efficient Waveband Translucent Optical Burst Switching Network," *Journal of Techniques*, vol. 4, no. 4, pp. 71–79, Dec. 2022, doi: 10.51173/JT.V4I4.776.
- [36] Singh, Rajat Kumar, and Yatindra Nath Singh. "An overview of photonic packet switching architectures." *IETE Technical Review* 23, no. 1, 15-34, 2006, <https://doi.org/10.1080/02564602.2006.11657928>.
- [37] G. de Valicourt et al., "Semiconductor Optical Amplifier for Next Generation of High Data Rate Optical Packet-Switched Networks," *Some Advanced Functionalities of Optical Amplifiers*, Dec. 2015.
- [38] K. Grobe, "Wavelength Division Multiplexing," *Encyclopedia of Modern Optics*, vol. 1, pp. 255–290, Jan. 2018, <https://doi.org/10.1016/B978-0-12-803581-8.09471-6>.
- [39] Y. Ji, J. Zhang, X. Wang, and H. Yu, "Towards converged, collaborative and co-automatic (3C) optical networks," *Science China Information Sciences*, vol. 61, no. 12, pp. 1–19, Dec. 2018, <https://doi.org/10.1007/s11432-018-9551-8>.
- [40] N. Andriolli et al., "Optical networks management and control: A review and recent challenges," *Optical Switching and Networking*, vol. 44, p. 100652, May 2022, <https://doi.org/10.1016/j.osn.2021.100652>.
- [41] Y. Zhao et al., "Software-Defined Optical Networking (SDON): Principles and Applications," *Optical Fiber and Wireless Communications*, Jun. 2017.
- [42] Klinkowski, Mirosław, and Marian Marciniak. "IP over optical network: strategy of deployment." *Journal of Telecommunications and Information Technology* 2, 51-56, 2001.
- [43] G. Wang et al., "c-Through," *ACM SIGCOMM Computer Communication Review*, vol. 40, no. 4, pp. 327–338, Aug. 2010, <https://doi.org/10.1145/1851182.1851222>.
- [44] H. Ballani et al., "Sirius: A Flat Datacenter Network with Nanosecond Optical Switching," *SIGCOMM 2020 - Proceedings of the 2020 Annual Conference of the ACM Special Interest Group on Data Communication on the Applications, Technologies, Architectures, and Protocols for Computer Communication*, pp. 782–797, Jul. 2020, <https://doi.org/10.1145/3387514.3406221>.
- [45] Mellette, William M., Rob McGuinness, Arjun Roy, Alex Forencich, George Papen, Alex C. Snoeren, and George Porter. "Rotornet: A scalable, low-complexity, optical datacenter network." In *Proceedings of the Conference of the ACM Special Interest Group on Data Communication*, pp. 267-280, 2017, <https://doi.org/10.1145/3098822.3098838>.
- [46] Ghobadi, Monia, Ratul Mahajan, Amar Phanishayee, Nikhil Devanur, Janardhan Kulkarni, Gireeja Ranade, Pierre-Alexandre Blanche, Houman Rastegarfar, Madeleine Glick, and Daniel Kilper. "Projector: Agile reconfigurable data center interconnect." In *Proceedings of the 2016 ACM SIGCOMM Conference*, pp. 216-229, 2016, <https://doi.org/10.1145/2934872.2934911>.
- [47] S. Lange et al., "Sub-nanosecond optical switching using chip-based soliton microcombs," *Optics InfoBase Conference Papers*, vol. Part

F174-OFC 2020, 2020, doi: 10.1364/OFC.2020.W2A.4.

- [48] A. Shakeri, M. Garrich, A. Bravalheri, D. Careglio, J. Solé-Pareta, and A. Fumagalli, "Traffic allocation strategies in wss-based dynamic optical networks," *Journal of Optical Communications and Networking*, vol. 9, no. 4, pp. B112–B123, Apr. 2017.
- [49] X. Xue, F. Yan, B. Pan, and N. Calabretta, "Flexibility Assessment of the Reconfigurable OPSquare for Virtualized Data Center Networks under Realistic Traffics," in *European Conference on Optical Communication, ECOC*, Institute of Electrical and Electronics Engineers Inc., Nov. 2018, <https://doi.org/10.1109/ECOC.2018.8535451>.
- [50] R. Goscienc, K. Walkowiak, and M. Klinkowski, "Distance-adaptive transmission in cloud-ready elastic optical networks," *Journal of Optical Communications and Networking*, vol. 6, no. 10, pp. 816–828, Oct. 2014.
- [51] A. Pal and K. Kant, "RODA: A reconfigurable optical data center network architecture," in *Proceedings - Conference on Local Computer Networks, LCN*, IEEE Computer Society, Dec. 2015, pp. 561–569, <https://doi.org/10.1109/LCN.2015.7366371>.
- [52] Liu, Chong, Maotong Xu, and Suresh Subramaniam. "A reconfigurable high-performance optical data center architecture." In *2016 IEEE Global Communications Conference (GLOBECOM)*, pp. 1-6. IEEE, 2016, <https://doi.org/10.1109/GLOCOM.2016.7841539>.
- [53] Gonzalez Sans, Xavier. "SDN-based control and orchestration of optical data centre networks." Master's thesis, Universitat Politècnica de Catalunya, 2019.
- [54] M. Abu-Tair et al., "Optical Space Switches in Data Centers: Issues with Transport Protocols," *Photonics* 2019, Vol. 6, Page 16, vol. 6, no. 1, p. 16, Feb. 2019, <https://doi.org/10.3390/photonics6010016>.
- [55] D. D. Le, L. P. Barry, D. C. Kilper, P. Perry, J. Wang, and C. McArdle, "AgileDCN: An Agile Reconfigurable Optical Data Center Network Architecture," *Journal of Lightwave Technology*, vol. 38, no. 18, pp. 4922–4934, Sep. 2020.
- [56] X. Xue et al., "Automatically reconfigurable optical data center network with dynamic bandwidth allocation," *Journal of Optics*, vol. 23, no. 11, p. 114003, Oct. 2021, <https://doi.org/10.1088/2040-8986/ac29cb>.
- [57] J. Che et al., "RGAlA: a reconfigurable AWGR based optical data center network," *Opt Express*, vol. 30, no. 13, p. 23640, Jun. 2022, <https://doi.org/10.1364/OE.457527>.
- [58] Xue, X., Calabretta, N. Nanosecond optical switching and control system for data center networks. *Nat Commun* 13, 2257 (2022). <https://doi.org/10.1038/s41467-022-29913-1>.
- [59] S. Lin, S. Zhang, X. Chen, and X. Nong, "Software-defined networking enabled optical data center network with flexible QoS provisioning," *Opt Commun*, vol. 530, p. 129129, Mar. 2023, <https://doi.org/10.1016/j.optcom.2022.129129>.
- [60] Z. Chen, Z. Zhao, Z. Li, J. Shao, S. Liu, and Y. Xu, "SDT: A Low-cost and Topology-reconfigurable Testbed for Network Research," Jul. 2023, Accessed: Sep. 24, 2023. <https://doi.org/10.1109/CLUSTER52292.2023.00036>.