



RESEARCH ARTICLE - MECHANICAL ENGINEERING

Elimination of Earing Defects in Square Cup Deep Drawing Using an Inverted Die Design for Different Materials

Rawa Hamid Al-Kalali¹, Ethar Mohamed Mubarak¹, Hassan A. Abdulhadi¹, Ghusoon Ridha Mohammed Ali^{1*}, Ali Hassan Saleh², Hamdi Habazi³, Ated Ben Khalifa³

¹Polytechnic College for Engineering – Baghdad, Middle Technical University, Baghdad, Iraq

²Engineering Technical College, Alfarqadein University, Basrah, Iraq

³National Engineering School of Monastir, University of Monastir, LGM, ENIM, Avenue Ibn-Eljazzar, 5019 Monastir, Tunisia

* Corresponding author E-mail: ghusoon_ridha@mtu.edu.iq

Article Info.	Abstract
<i>Article history:</i>	The deep-drawing process for square cups is primarily used in sheet metal production, but it is associated with several defects, such as tearing, earing, and wrinkling. This research intends to optimize the square deep drawing process to minimize or eliminate earing defects using an inverted deep drawing die design and to produce an optimal cup (without defects). Thus, the design and manufacture of the inverted deep-drawing die for the production of square cups are carried out experimentally and by the finite element method using the ANSYS program. The investigation is carried out by conducting several experiments using three metals (low carbon steel st1008, brass CuZn30, and aluminum A1100). The metal thickness is 0.7mm, and the materials are characterized by tensile testing and mechanical properties, including Young's modulus and yield stress. Experimental tests have been carried out under various load conditions for the empty holder. A three-dimensional square-cup model (43mm by 43mm) with a (0.7mm) thickness is built. Given the sample's symmetrical geometry, only one-fourth of the model needed to be analyzed. The minimum Blank Holding Force (BHF) for steel and brass sheets is higher than that required for aluminum sheets. The percentage difference between the experimental punch force and ANSYS test results is 7.4% for steel, 9% for brass, and 6.5% for aluminum. An important thing to note during the formation of square cups is that the deformation conditions in the die's hollow change. In fact, the corners of the cup are subject to greater deformation than the sides, because during distortion the metal on the sides of the cup moves more uniformly and more easily than in the corners.
Received 03 March 2026	
Revised 02 June 2026	
Accepted 09 June 2026	
Published 30 June 2026	

This is an open-access article under the CC BY 4.0 license (<http://creativecommons.org/licenses/by/4.0/>)

Publisher: Middle Technical University

Keywords: Deep Drawing Process; Finite Element Method; Mechanical Properties; ANSYS, Square Die Design; Earing; Blank Holder Force.

1. Introduction

Most modern industrial activities, such as car assembly, aviation, and electrical power design, rely on deep-drawing technology to produce non-axisymmetric parts. For example, deep drawing of square cups is used in various applications, such as the assembly of vehicle parts and the manufacture of steel kitchen sinks [1, 2]. The deformation mechanism of the square cups is somewhat different from that of the round cups. The process of square cup formation is a complex deformation mechanism. When shaping square cups, it is important to note that the distortion states fluctuate along the pass-on die cavity while the corners of the square cup experience biaxial compression and tension in the flange; the corners of the walls experience more straightforward uniaxial tension [3]. Considering these, the cup side walls experience greater bending and straighten under the influence of uniaxial tension. Hence, the metal progression is simpler, higher, and more uniform at the cup walls than in the corners [4, 5]. Because of the differences in metal flow rate and tangential compression of the blank through the die cavity, materials normally assemble in the corners of the cup. The deflection is nearly accumulated at the cup corners and causes a crack [6].

Fan et al. [7] examined the improvement of damage and the arrangement of wrinkles under the impacts of the blank holding power and Coulomb friction. Trials were conducted to form square segments 1 mm thick from a mild steel blank. The researchers presumed that the cracks started at the area where the punch corner imparted a large wrap distortion, then moved closer to the blank edge, where wrinkling occurred. Müller et al. [8] used Flat sheets in the deep drawing process to create three-dimensional components. Through microstructural effects (such as anisotropy, residual stresses, voids, and lattice defects), the deep drawing process affects the material properties of the sheets. The ensuing effects, particularly voids and lattice flaws, affect the component's evolution and damage accumulation. Different load paths, driven by the process route and other factors, result in different progression paths for damage.

Nomenclature and Symbols			
APDL	ANSYS Parametric Design Language	A	Outer Diameter (mm)
FEM	Finite Elements Method	H	Height of Cup (mm)
ASTM	American Society for Testing and Materials	r	Profile Radius of cup (mm)
EDM	Electrical Discharge Machining	r_p	Punch Edge Radius (mm)
FBH	Force Applied via Blank Holder (N)	D	Blank Diameter (mm)
ABH	Surface Pressurized by Blank Holder (mm ²)	d_p	Punch Diameter (mm)
P	Blank Holder Pressure (N/mm ²)	σ_u	Ultimate Tensile Stress (N/mm ²)

The impact of process parameters (drawing ring radius) and process setup (multi-step deep drawing and reverse drawing) during deep drawing, along with the corresponding load routes, on damage evolution in rectangular cups manufactured from dual-phase steel DP800, was examined numerically in this work.

Gavas and Izciler [9] examined the “effect of blank holder gap on” the quality of forming of the component by drawing square cups using 1 mm thick aluminum sheets. In another study, Gavas [10] used an anti-lock braking system to improve the formability of a conical square cup. To prevent thinning and wrinkles, Choudhari and Khasbage [11] present experimental validation and numerical analysis of the deep drawing process. The impact of various drawing parameters, including blank shape, blank thickness, load, and dry/wet lubrication, on the square cup drawing process using extra-deep-drawn (EDD) steel sheet material is examined using both numerical and experimental methods. Experiments are used to validate simulation results using computer-aided engineering (CAE) software. Using the forming limit diagram (FLD), formability is analyzed for the laser-engraved circular grids on the blank surface. A square cup, free of flaws such as wrinkles and thinning, was formed thanks to the optimized process parameters. Experimental and formability analyses revealed that, under 100 kN load with dry lubrication, the formability of a material with a blank thickness of 2 mm is superior to that with 1 mm or 0.8 mm for the process parameters considered. Hezam et al. [4] presented an improved procedure to increase the formability of square cups. They used a tool without a blank holder or beds, consisting of a flat-headed punch and a conical die with a square opening at its end. The process was performed on brass (CuZn33) and pure aluminum of different thicknesses and diameters at the conical die angle of 360. Modi and Ravi [12] designed and developed an experimental setup for the hydroforming deep drawing of square cups, which used fluid pressure to deform the blank into the die cavity of the required shape. The methodology was established to determine the minimum required blank holder force for the hydroforming of AA5182 alloy.

Hassan et al. [13] developed a tapered circular blank holder split into eight pieces to improve square cup drawability. During deep drawing operations, the eight segments are divided into two sections based on their movements. The outcomes demonstrated that the new system could produce square cups from 0.5 mm-thick aluminum sheets with a large drawing ratio of 3.3. Katahira [14] investigated the drawability of deep drawing for a square AZ31 Alloy sheet of magnesium at different temperatures (ranging from ambient temperature to 200 °C) at 3 different punch speeds (3, 30, and 300 mm/min). Harada and Minoru [15] evaluated the formability of unalloyed titanium sheets in a multi-stage square deep-drawing process.

Ogawa et al. [16] analyzed the deep-drawing process for square cups to predict the formability of pure titanium. The analysis was performed using the finite element method with solid elements. The FEM results were compared with the experimental results to validate the analysis. Ozek and Akkelek [17] used the finite element method (FEM) and experimentation to investigate the numerical shaping of rectangular cups in angled deep-drawing dies. To facilitate material flow into the die cavity, the die/blank holder surfaces have angles of $\alpha = 0^\circ, 3^\circ, 6^\circ, 9^\circ, 12^\circ,$ and 15° . The die and punch corner radii are assumed to be 8 mm. The test material was a 0.9 mm thick sheet of St37 steel. Die/blank holder forces of 2500 N, 5000 N, 7500 N, and 10000 N were applied during the experiments. The ideal punch force was found by experimentally and numerically examining the effects of angles and die/blank holder force on limit draw ratio, wall thickness, and cup damage. ANSYS results and the obtained experimental results were compared. Consequently, it has been found that a higher limit is achieved by increasing the die/blankholder surface angles in rectangular-geometry drawing dies. Vairavan and Abdullah [18] investigated the pattern of thinning during the deep drawing of 0.6 mm thick aluminum (A1100) square cups, focusing on the effect of alignment error between the punch and die. Younis et al. [19] focused on the influence of die profile radius, blank diameter, and clearance between punch and die on thickness distributions and height of cups.

According to the literature, square deep drawing frequently causes defects such as wrinkling, tearing, and uneven thinning, which typically start at the punch corners and near the blank edge. Material drawability is largely determined by factors like drawing speed, die/blank holder surface angles, lubrication, and blank holding force (BHF). The drawing limit can be improved by increasing the die/blank holder surface angles and using appropriate lubrication, in conjunction with increased blank thickness (e.g., g. 2 mm). This has been demonstrated to yield components that are noticeably more reliable and flawless. Finite Element Method (FEM) simulations are now a vital tool for failure prediction and setup forming path optimization. In this research, an inverted deep drawing of a square cup from sheet metal with a blank holder is experimentally investigated and simulated using finite element analysis in ANSYS 15. The materials used are aluminum A1100, brass CuZn30, and low-carbon steel St1008.

2. Deep Drawing of Square Cup

Deformation occurs equally along the blank circumference when deep-drawing circular parts, while deep-drawing of noncircular components induces the highest stresses and strains at the corners; however, fewer strains and stresses occur in the walls. The walls are not only bent but also experience tangential compressive and radial tensile stresses [20, 21]. The metal flow at the cup corners is similar to that in an axisymmetric deep-drawing process, as the walls bend and unbend. Rupture typically happens in the corner wall region of the cup. A higher blank holder is required to overcome the compressive stresses in the corners than to overcome the bending forces in the sides. Thus, the corner wall regions experience higher stresses than the sidewalls. Furthermore, the corner flange tends to thicken more than the side flange. Localized necking and ductile fracture mechanism involving significant plastic deformation, beginning with micro-void nucleation at inclusion, followed by void growth linkage (coalescence) and by final shear failure. This process often creates a fracture surface of the "cup and cone" type or occurs under stresses in a reduced area, resulting in localized strain. As a result, the blank holder pressure is concentrated in the corner flange areas and further increased. It is desirable to have a blank holder force that varies across the flange area to elastically deflect the blank holder, promoting

drawing and improving part quality. More blank holder force is needed in the corners than in the sides to suppress the wrinkling that tends to occur in the corners because of circumferential compressive stresses [22]. It is conceivable to apply the guidelines for drawing circular segments to the drawing of non-circular parts by supplanting the punch and the blank regions with circles of equivalent sizes and ascertaining their equal radii [23, 24]. The limiting drawing ratio follows the same trend as for drawing circular parts and increases with increasing relative sheet thickness. The equivalent diameters can also be used to determine the drawing loads for square components. To form square parts of great heights, suitable drawing increments must be chosen [25].

3. Experiments

3.1. Square cups details

The components for investigating metal flow during the drawing process are steel, brass, and aluminum square cups. The dimensions of the deep drawn components are as follows: height of cup (h) = 20 mm, corner wall radius (r) and bottom edge radius (r_p) = 5 mm, and outer dimension (a) = 43 mm.

3.2. Chemical composition of used materials

The properties of the drawn materials significantly affect the success of the drawing process. Three different raw materials, aluminum Al1100, brass CuZn30, and low carbon steel St1008 of 0.7 mm thickness were utilized in this study to produce various blanks for square deep drawing experiments. The chemical composition of the three materials was tested using an atomic absorption spectrometer at the State Company for Inspection and Engineering Rehabilitation SIER laboratory, and the results are listed in Table 1.

Table 1. Chemical composition of St 1008, Al 1100, and CuZn30

Element (wt.%)	Material		
	Low Carbon Steel	Brass CuZn30	Aluminum 1100
Carbon	0.03770	-	-
Silicon	0.02350	-	0.0535
Manganese	0.2170	-	0.0045
Phosphorus	0.02050	0.00480	-
Sulphur	0.00670	-	-
Chromium	0.04530	-	0.0026
Molybdenum	<0.0020	-	-
Nickel	0.02720	0.00170	<0.0026
Aluminum	0.0460	-	Bal.
Copper	0.06240	69.100	0.003
Iron	Bal.	0.0570	0.305
Zinc		30.780	<0.001
Lead		0.00680	<0.0005
Tin		0.00260	-
Titanium			0.0124
Magnesium			0.0008

3.3. Tensile test of used materials

The mechanical properties of the three materials were determined by tensile testing on a universal testing machine at SIER. The test specimens were prepared according to ASTM E8 [26] and produced using a wire-cut Electrical Discharge Machine (EDM). The EDM is an electro-thermal process that uses an electrode and electrical sparks to cut through metals. It can only be used on materials that can conduct electricity. Table 2 presents the necessary properties of the metals used in this study.

Table 2. Material properties of St 1008, Al 1100, and CuZn30

Properties	Material		
	Low Carbon Steel	Brass CuZn30	Aluminum1100
Yield stress (MPa)	203	163.04	112
Tensile strength (MPa)	360.5	328.17	130.2
Young modulus (GPa)	200	114	70
Poisson ratio	0.3	0.34	0.33
Elongation%	23.24	33.33	2.3

3.4. Design and manufacturing of the inverted square deep-drawing process

Punch and die were designed and built to produce a square cup, as seen in Fig. 1. The die was made of high-carbon, high-chromium cold-work tool steel D3 (X210 CrW12). The outer dimensions were 120 x 120 mm, and the inner dimensions were 43 x 43 mm with a profile and corner radii of 5 mm. The punch-die clearance was set to 1.1 mm. To ensure there is no misalignment, the die was designed with an edge for positioning it in the blank holder. The punch was fixed to the lower plate; the dimensions of the punch used were 40.7 x 40.7 mm with corner and profile radii of 5 mm. It was made of D3 Tool steel (X210 CrW12). The blank holder system consisted of a blank holder, compression pins, a spring, a column, and movable and fixed spring plates. The blank holder was designed to be slide-fitted with a punch and had a groove to locate the blank and position the die. The blank holder force was produced by a compression spring; the connection between the blank holder and the movable spring plate was achieved with compression pins fed through the lower plate. The spring column was attached to the lower plate, which hangs in a cut-out of the lower plate. The materials used for the blank holder and compression pins, moveable and fixed spring plates, and lower plate, and spring were medium carbon steel C45 steel, mild steel, and oil tempered carbon, respectively. The outer and inner dimensions of the blank holder were 120 x 120 mm and 40.9 x 40.9 mm, respectively, and the clearance was 1.1 mm.

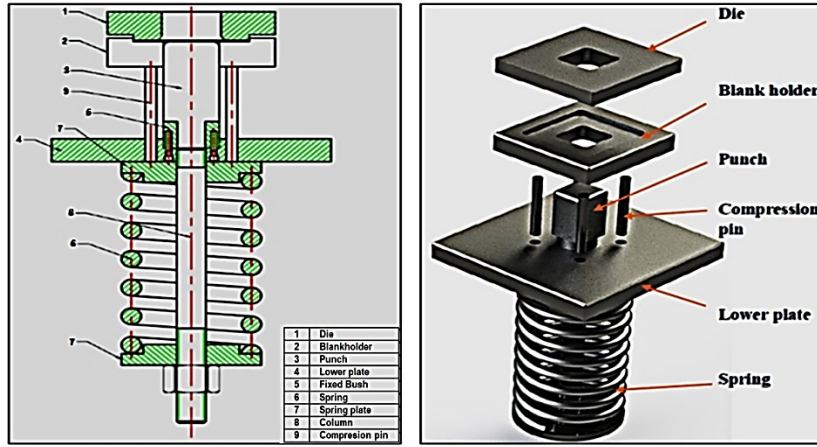

Fig. 1. The designed and manufactured inverted square deep-drawing process

3.5. Deep drawing test

Deep-drawing experiments were performed to obtain square cups by construction, as shown in Fig. 2; the deep-drawing die was placed on a hydraulic press with a capacity of 220 kN. After putting the blank on the blank holder surface, and considering the rolling direction of the sheet, the die will drop towards the punch, and this means the use of an inverted drawing die [27]. The drawing speed used was 9 mm/min. The force of the blank holder needed for the deep drawing process was determined using equations (1) and (2) [28, 29]:

$$P = 0.002 \text{ to } 0.003 \left[\left(\frac{D}{dp} - 1 \right)^3 + 0.005 \frac{dp}{t} \right] \sigma_u \quad (1)$$

The force applied via the blank holder was determined through the pressure of the blank holder and the pressurized surface via the blank holder *ABH*:

$$FBH = P * ABH \quad (2)$$

ABH = surface pressurized by the blank holder or the blank area which is in contact with the blank holder (mm²).

P = Blank holder pressure (N/mm²).

The blank holder pressure value for every single sheet is as follows:

For steel, *P* = 1.23 MPa

For brass *P* = 1.05 MPa

For Aluminum *P* = 0.42 MPa

A load of blank holding was determined to cancel the wrinkling.



Fig. 2. The machine tool used for deep drawing experiments

3.6. Strain measurement

To examine the distribution of strain within the cup during the drawing process, a grid pattern of circular radius 5 mm was plotted on the undeformed blanks using the marker as shown in Fig. 3. In the present research, the strain along diagonal and transverse directions at various curvilinear distance from the centre of the blank at an interval of 5 mm are measured using micrometre and AutoCAD and the corresponding strain are calculated. Radial strain is calculated by measuring the deformed grids on the deep-drawing component along the major axis. The hoop or circumferential strain is calculated by measuring the length of the minor axis of the ellipse. Grid measurements can be performed using image processing in AutoCAD software.



Fig. 3. Grid pattern before and after the deformation

3.7. Case studies

Blank sheets were deformed into square cups under various conditions. Table 3 lists the case studies investigated in this work.

Table 3. Cases studies

	Materials	Blank dia. (mm)	Parameters Thick (mm)	Clear. (mm)	Lubric. type
Case1	Low Carbon Steel	85	0.7	1.1	Sunflower Oil
Case2	Brass CuZn30	85	0.7	1.1	Sunflower Oil
Case3	Aluminum1100	85	0.7	1.1	Sunflower Oil

3.8. Simulation of the inverted deep-drawing process

ANSYS 15, a multi-purpose linear and nonlinear FEM analysis program, was used in this study to develop the finite element analysis in a manner that captures the actual forming procedure. APDL-ANSYS Command files were created to simulate the deep-drawing process using a square die [30]. The 3D model was also constructed. Due to the geometry and loading conditions of the general problem, it can be sensibly approximated by an asymmetric model. In the simulation, Hill's yield criteria were used, and the "Newton-Raphson" implicit method was used to address the nonlinearity. In this methodology, the characterization of the stroke steps on the instrument was performed over a range of time intervals. Few arrangements (sub-steps or time steps) were performed in each progression to apply the dislodging gradually [31, 32]. At each sub-step, various balance cycles were performed to achieve convergence. The Newton-Raphson strategy was used to assess the out-of-balance vector of the loads before each arrangement, which is the difference between the residual loads (the forces associated with the element stresses) and the applied forces. Then, the program used the out-of-balance forces to implement a direct arrangement while checking the convergence. It has reconsidered the out-of-balance load vector for the off-chance criteria that were not fulfilled; the stiffness matrix was refreshed, and another arrangement was obtained. This iterative system proceeded until the problem converged. The three-dimensional solid element Solid185 with 8 nodes was used to mesh the blank [26]. The die-and-punch set was modelled as rigid bodies [27]. A pilot node was used to define the punch movement and the holding force. The interference between the blank and tooling was generated using the automatic contact process in ANSYS 15.0. Because of the symmetric geometry of the blank, as well as the constraints and boundary conditions, a quarter portion of the model needed to be analysed. The geometry of the deep-drawing process used in the simulation is shown in Fig. 4.

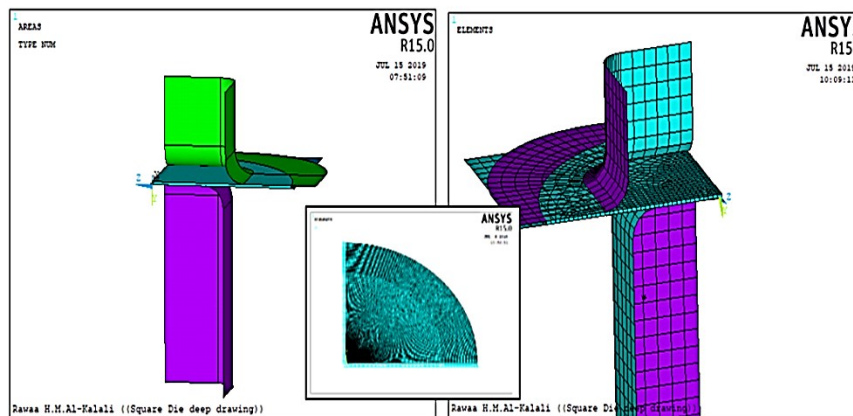

Fig. 4. ANSYS model for inverted deep-drawing process with quarter plot, mesh, and contact area

4. Results and Discussion

4.1. Blank holder force

The drawability of sheet metals is primarily determined by the blank holder force; therefore, it is important to select the appropriate blank holder force. When the blank holder force is insufficient, wrinkling may occur; when too high, tearing or fracture may occur, as shown in Fig. 5.

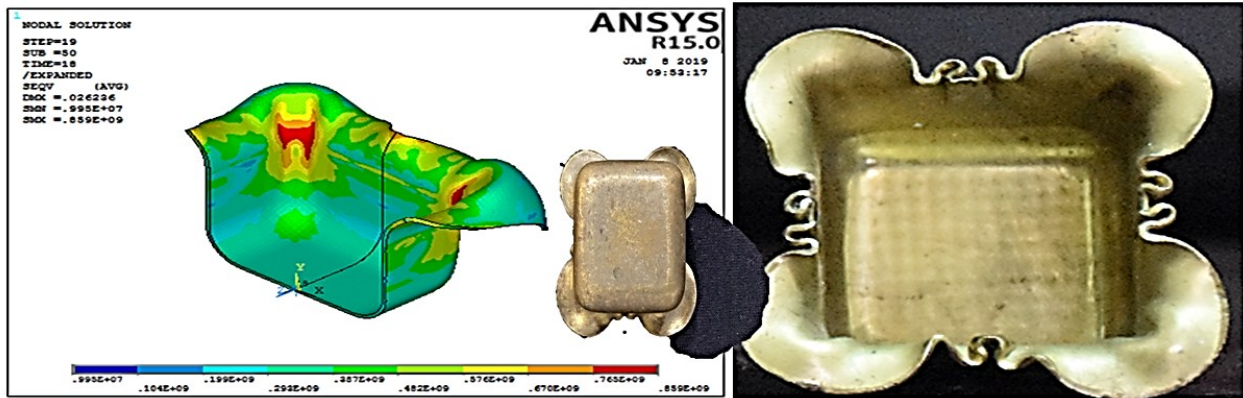

Fig. 5. Sheet metals affected by the load of the blank holder

For each blank, many deep-drawing tests were performed with various blank holder loads ranging from the low value (which causes wrinkling) to the value that prevents wrinkling. For each blank, experimental tests and ANSYS analyses were performed at different Blank Holder Forces (BHF). For steel sheets with a thickness of 0.7 mm, the wrinkling occurred when a BHF of 2.2 kN was used in the experiment and 2.5 kN in the FE simulation. By increasing the value of BHF to 5.1 kN in the experiments and to the BHF of 5.5 kN in the FE simulation, an attractive part with no wrinkling was generated.

For the brass sheet blank, wrinkling occurred when a blank holder force (BHF) of 1.8 kN was used in the experiment and 2.2 kN in the simulations. The proper part was produced when using BHF of 4.6 kN in the experiment and 5.1 kN in the finite element. In both experimental and FE investigations on aluminium sheets of 0.7 mm thickness, a lower BHF of 1.85 kN in the experiments and a lower BHF of 2.7 kN in finite element simulations were needed to produce an adequate model. Using BHF of 0.5kN and 0.7kN caused wrinkling in the experiment and FE simulation, respectively. Based on the experiment and FEM results shown in Table 4, the minimum value of BHF for steel and brass sheets was higher than the value needed for aluminium sheets. Hence, it can be observed that the sheet with a large strength needs more BHF than the sheet with lower strength [33, 34]. Also, the lower BHF can be used for a sheet with greater ductility to control wrinkling. The wrinkles were formed due to the appearance of an insufficient blank holder load and rupture at the punch radius zone due to excessive stress [28].

Table 4. Experimental and ANSYS results of the blank holder force

Materials	Blank holder Force kN	
	Experimental	ANSYS
Steel	5.1	5.5
Brass	4.6	5.1
Aluminium	1.85	2.7

4.2. Punch load-displacement curves

The experimental and FEA punch load-displacement curves for all the studied cases are shown in Fig. 6. These curves generally exhibited similar trends; there was an almost linear increase in punch force, reaching a maximum at punch stroke values of 35-41%. Then, a progressive decrease in punch force was observed at a stroke value of around 66%. Later, there was an increase in punch force due to the ironing of the thickened edge and drawing of the remaining flange (cup corner) [35]. The forming load for the steel plate was higher than the required forming loads for aluminium and brass sheets, as shown in Fig. 7. The percentage deviation between the experimental results and ANSYS results was 7.4% for steel, 9% for brass, and 6.5% for aluminium.

4.3. Strain and stress distribution

Fig. 7 shows the experimental and ANSYS results of the radial strain distributions along with diagonal directions. The major axis (radial direction) and the minor axis (circumferential direction) of the elliptical grids formed by the deformation of the circular grids were measured at various curvilinear distances from the centre of the blank. The percentage strain variations at the cup's bottom are negligible, possibly because no cold work was performed in these regions. The radial strain began to increase from the punch radius area of the drawn cup towards the cup end due to the tension stress. Fig. 8 illustrates the deformation, strain, and stress distribution in the inverted square die deep drawing [36, 37].

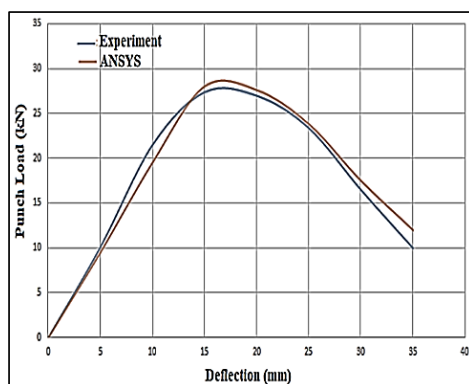

(a) Brass

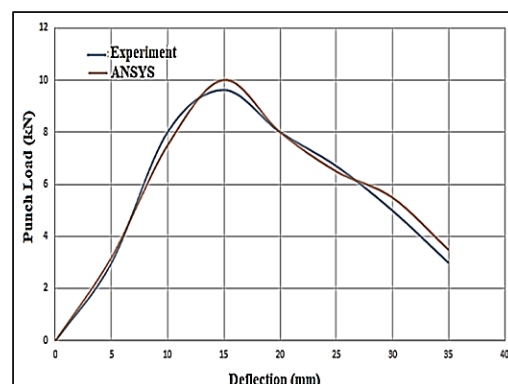

(b) Aluminium

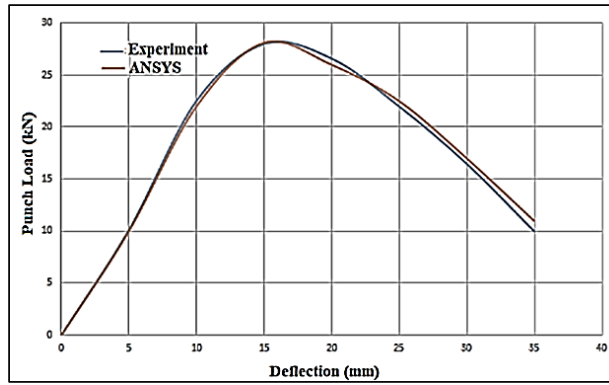

(c) Steel

Fig. 6. Punch load-displacement

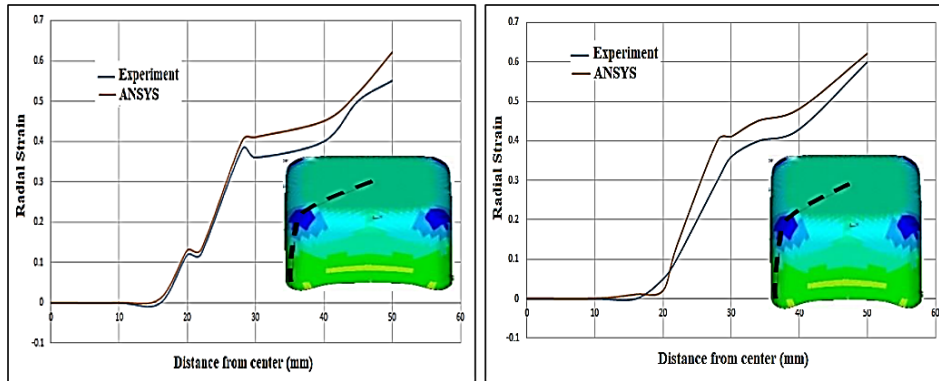

(a) Brass

(b) Aluminium

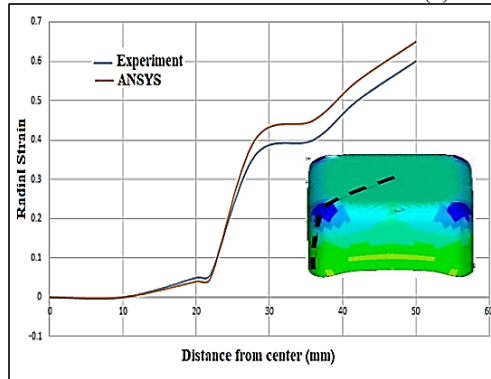

(c) Steel

Fig. 7. Radial strain distribution

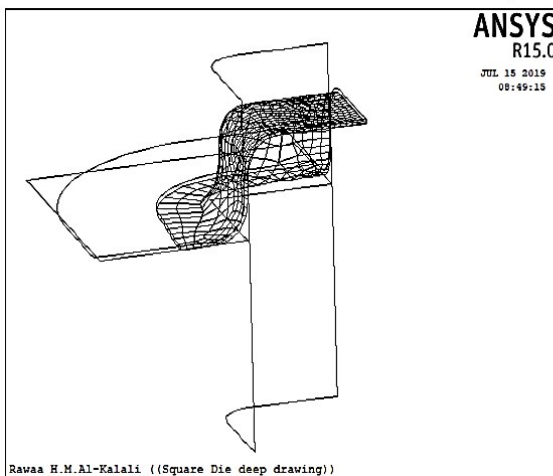

(a) Finite element model

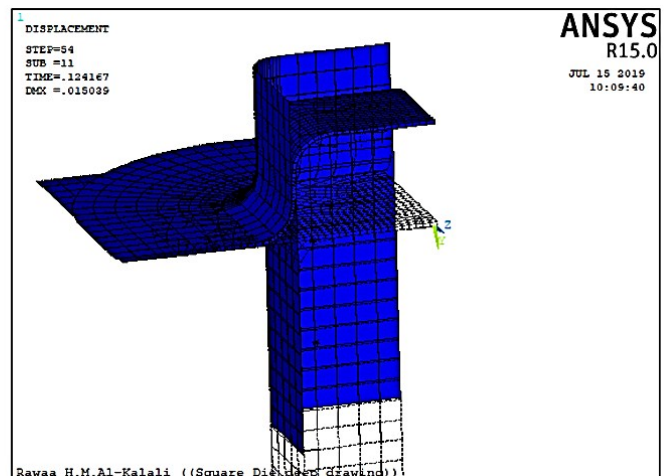

(b) Meshed finite element model

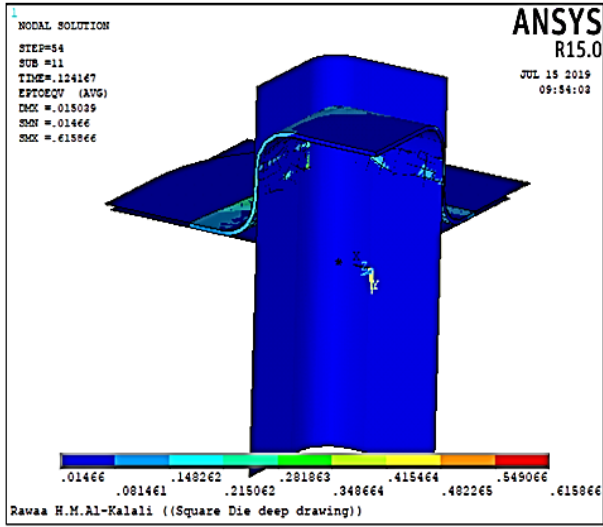

(c) Strain distribution (Steel)

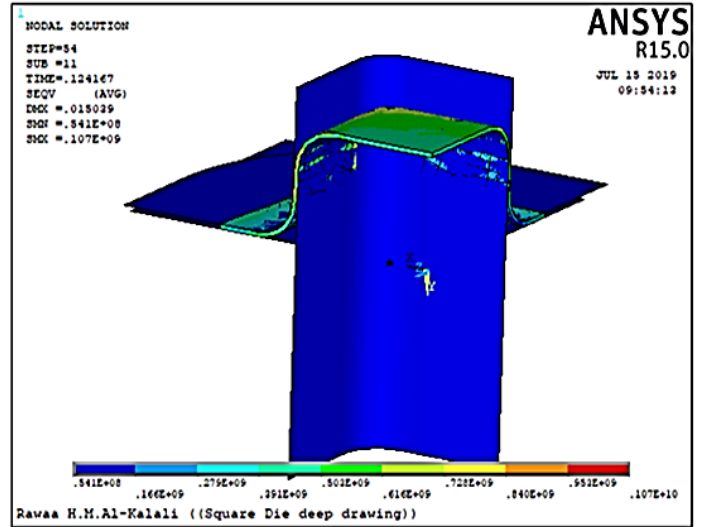

(d) Stress distribution (Steel)

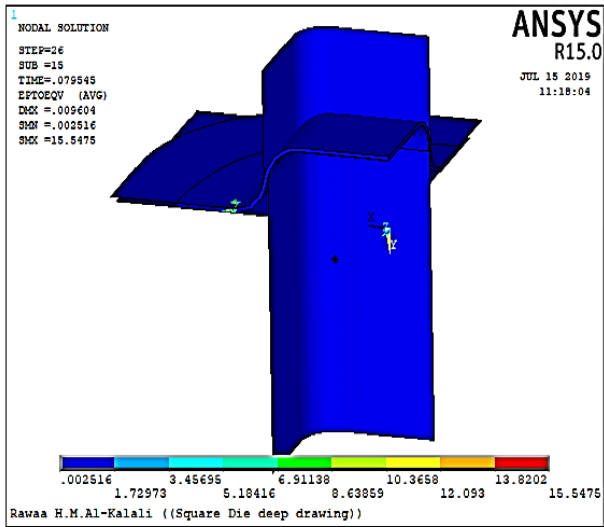

(e) Strain distribution (brass)

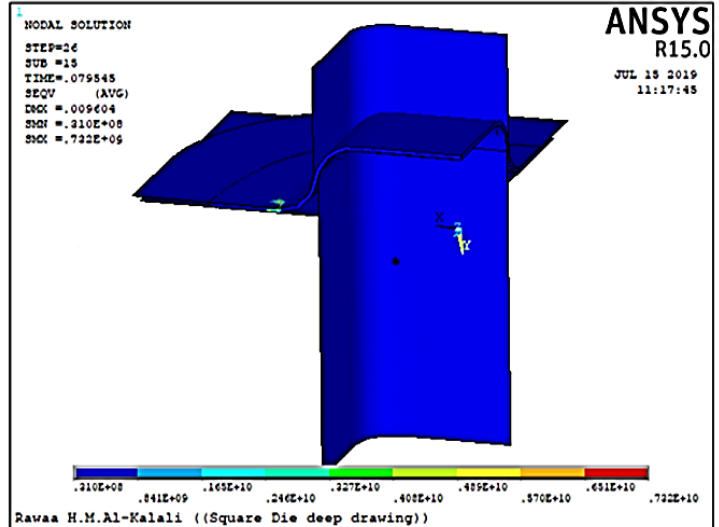

(f) Stress distribution (brass)

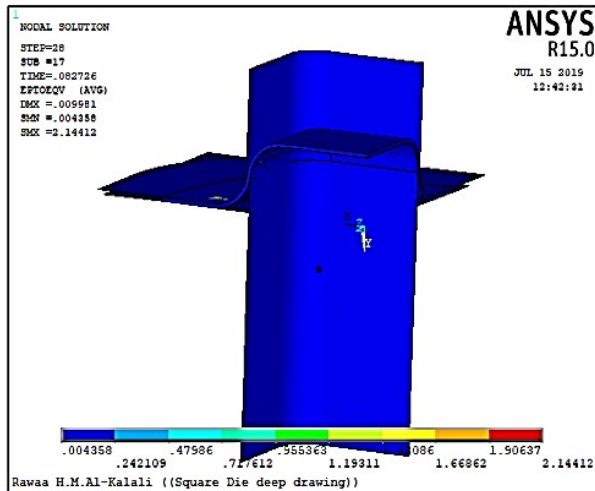

(g) Strain distribution (Aluminium)

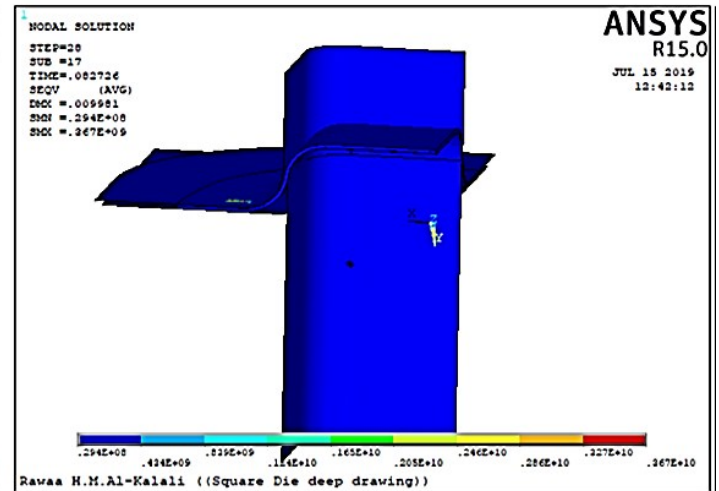

(h) Stress distribution (Aluminium)

Fig. 8. The deformation, strain, and stress distribution

5. Conclusions

The current study intended to optimize the square deep-drawing process in order to minimize or eliminate earing defects using an inverted deep-drawing die design. By integrating the finite element method into ANSYS, the study successfully predicted optimal blank holder forces to reduce defects in low-carbon steel, brass, and aluminum. The following conclusions have been made:

- There were significant variations in the deformation states along the die cavity; a more uniform and simple metal flow was observed at the cup side walls compared to the cup corner; hence, there was more concentration of the earing defect at the cup corners.
- Steel requires the highest forming load, followed by brass, then aluminium.
- Higher-strength materials like steel require more force to prevent wrinkling, and experimental and FEA results show that optimal deep drawing requires balancing blank holder force with material ductility to prevent defects.
- The punch force rises linearly until it reaches its maximum at a punch stroke of between 35% and 41 %. At about 66 %, there is a progressive drop in force. The ironing of thickened edges and the drawing of the remaining flange at the cup corner cause the force to increase once more.
- The percentage deviation between the experimental results and ANSYS results is small, measuring 7.4% for steel, 9% for brass, and 6.5% for aluminium.
- Radial strain began increasing from the punch radius of the drawn cup towards the cup end due to tensile stress.
- The process shows a highly localized strain distribution, a predictable three-stage load behavior, and good agreement between physical trials and ANSYS simulations.
- The current study's comprehensive integration of finite element modeling greatly advances the industry toward cost-effective, defect-free, and automated manufacturing by combining empirical data with highly accurate simulation technologies.

6. Recommendation for Future Work

The following recommendations are necessary for future work:

- The study can be extended to compound materials like stainless steel-copper laminated sheets or metal-polymer-metal sandwich sheets.
- Study of the drawability of the sheet through the reverse deep drawing die without the blank holder or through a conical die with a square aperture.
- Study the effect of Teflon film lubricant on the forming load and strain distribution.
- Study the effect of draw-beads on the deep-drawing process for square cups.

Acknowledgment

The authors gratefully acknowledge the support and guidance provided by the Polytechnic College for Engineering – Baghdad, Middle Technical University, Baghdad, Iraq, as well as the contributions of all individuals who offered advice during the development of this research.

References

- [1] M. Gavas and M. Izciler, "Design and application of blank holder system with spiral spring in deep drawing of square cups," *Journal of Materials Processing Technology*, vol. 171, pp. 274-282, 2006. <https://doi.org/10.1016/j.jmatprotec.2005.06.082>.
- [2] R. Dwivedi, A. K. Choubey, R. Purohit, and R. S. Rana, "Experimental and numerical analysis of aluminium alloy cylindrical cup using novel deep drawing technique," *Advances in Materials and Processing Technologies*, vol. 8, pp. 1831-1844, 2022/04/03 2022. <https://doi.org/10.1080/2374068X.2021.1878701>.
- [3] G. R. Mohammed Ali, A. Z. Ridha, D. A. Sadeq, A. A. Ebraheem, and A. S. Atta, "Effect of Ultrasonic Peening on Mechanical Properties of Low Carbon Steel AISI 1020 TIG Welding Joints Process," *International Journal of Applied Mechanics and Engineering*, vol. 27, pp. 194-204, 2022. <https://doi.org/10.2478/ijame-2022-0059>.
- [4] L. M. A. Hezam, M. A. Hassan, I. M. Hassab-Allah, and M. G. El-Sebaie, "Development of a new process for producing deep square cups through conical dies," *International Journal of Machine Tools and Manufacture*, vol. 49, pp. 773-780, 2009/08/01/ 2009. <https://doi.org/10.1016/j.ijmachtools.2009.04.001>.
- [5] A. K. Choubey, G. Agnihotri, and C. Sasikumar, "Experimental and mathematical analysis of simulation results for sheet metal parts in deep drawing," *Journal of Mechanical Science and Technology*, vol. 31, pp. 4215-4220, 2017/09/01 2017. <https://doi.org/10.1007/s12206-017-0819-4>.
- [6] R. M. Ghusoon, H. M. Rawaa, and H. A. Basim, "Effect of die geometry on thermal fatigue of tool steel in aluminium alloy die-casting," *IOP Conference Series: Materials Science and Engineering*, vol. 518, p. 032042, 2019/05/01 2019. <https://doi.org/10.1088/1757-899X/518/3/032042>.
- [7] J. P. Fan, C. Y. Tang, C. P. Tsui, L. C. Chan, and T. C. Lee, "3D finite element simulation of deep drawing with damage development," *International Journal of Machine Tools and Manufacture*, vol. 46, pp. 1035-1044, 2006/07/01/ 2006. <https://doi.org/10.1016/j.ijmachtools.2005.07.044>.
- [8] M. Müller, I. F. Weiser, T. Herrig, and T. Bergs, "Numerical Prediction of the Influence of Process Parameters and Process Setup on Damage Evolution during Deep Drawing of Rectangular Cups," *Engineering Proceedings*, vol. 26, p. 6, 2022. <https://doi.org/10.3390/engproc2022026006>.
- [9] M. Gavas and M. Izciler, "Effect of blank holder gap on deep drawing of square cups," *Materials and Design*, vol. 28, pp. 1641-1646, 2007/01/01/ 2007. <https://doi.org/10.1016/j.matdes.2006.03.024>.
- [10] M. Gavas, "Increasing the drawing height of conical square cups using anti-lock braking system (ABS)," *Journal of Mechanical Science and Technology*, vol. 23, pp. 3079-3087, 2009/11/01 2009. <https://doi.org/10.1007/s12206-009-0911-5>.
- [11] C. S. Choudhari and S. S. Khasbage, "Experimental investigation of forming parameters for square cup deep drawing process," *Materials*

- Today: Proceedings, vol. 44, pp. 4261-4267, 2021. <https://doi.org/10.1016/j.matpr.2020.10.543>.
- [12] B. Modi and D. R. Kumar, "Development of a hydroforming setup for deep drawing of square cups with variable blank holding force technique," The International Journal of Advanced Manufacturing Technology, vol. 66, pp. 1159-1169, 2013/05/01 2013. <https://doi.org/10.1007/s00170-012-4397-4>.
- [13] M. A. Hassan, K. I. E. Ahmed, and N. Takakura, "A developed process for deep drawing of metal foil square cups," Journal of Materials Processing Technology, vol. 212, pp. 295-307, 2012/01/01/ 2012. <https://doi.org/10.1016/j.jmatprotec.2011.09.015>.
- [14] T. Katahira, T. Naka, Y. Nakayama, R. Hino, and F. Yoshida, "Effects of Temperature and Forming Speed on Square Cup Drawability of AZ31 Magnesium Alloy Sheet," Advanced Materials Research, vol. 871, pp. 211-214, 2014. <https://doi.org/10.4028/www.scientific.net/AMR.871.211>.
- [15] Y. Harada and M. Ueyama, "Multi-Stage Cold Deep Drawing of Pure Titanium Square Cup," Key Engineering Materials, vol. 651-653, pp. 1072-1077, 2015. <https://doi.org/10.4028/www.scientific.net/KEM.651-653.1072>.
- [16] T. Ogawa, N. Ma, M. Ueyama, and Y. Harada, "Analysis of Square Cup Deep-Drawing Test of Pure Titanium," Journal of Physics: Conference Series, vol. 734, p. 032072, 2016/08/01 2016. <http://dx.doi.org/10.1088/1742-6596/734/3/032072>.
- [17] C. Ozek and H. Akkelek, "Investigation of Deep Drawability of Rectangular Shaped Cups in Deep Drawing Dies," International Journal of Innovative Engineering Applications, vol. 5, pp. 187-194, December 2021. <https://doi.org/10.46460/ijiea.1006144>.
- [18] H. Vairavan and A. B. Abdullah, "Die-punch alignment and its effect on the thinning pattern in the square-shaped deep drawing of aluminium alloy," International Journal of Materials and Product Technology, vol. 54, pp. 147-164, 2017. <https://doi.org/10.1504/IJMPT.2017.080565>.
- [19] K. M. Younis, A. S. Jabber, and M. M. Abdulrazaq, "Experimental Evaluation and Finite Element Simulation to Produce Square Cup by Deep Drawing Process," Al-Khwarizmi Engineering Journal, vol. 14, pp. 39-52, 2018. <https://doi.org/10.22153/kej.2018.10.002>
- [20] G. R. Mohammed, E. M. Mubarak, and B. H. Abbas, "Thermal fatigue model of aluminium alloy die casting H-13 dies under thermo-mechanical cycle," Mechanics, vol. 27, pp. 385-391, 2021. <https://doi.org/10.5755/j02.mech.25765>.
- [21] H. E. Theis, Handbook of metalforming processes: CRC Press, 1999.
- [22] Z. Huda, Metal Forming Processes: Fundamentals, Analysis, Calculations: Springer, 2024.
- [23] H. A. Youssef, H. A. El-Hofy, and M. H. Ahmed, Manufacturing technology: materials, processes, and equipment, 2nd Edition ed.: Crc Press, 2023. <https://doi.org/10.1201/9781003373209>.
- [24] I. Suchy, Handbook of die design 2nd Edition vol. 1998: McGraw-Hill New York, 2006.
- [25] A. E. Tekkaya, "Metal Forming" in Springer Handbook of Mechanical Engineering, K.-H. Grote and H. Hefazi, Eds., ed Cham: Springer International Publishing, pp. 357-408, 2021. https://doi.org/10.1007/978-3-030-47035-7_11.
- [26] E. Gdoutos and M. Konsta-Gdoutos, "Tensile Testing," in Mechanical Testing of Materials, ed Cham: Springer Nature Switzerland, 2024, pp. 1-34. https://doi.org/10.1007/978-3-031-45990-0_1.
- [27] W. F. Hosford and R. M. Caddell, Metal forming: mechanics and metallurgy, Fourth Edition ed.: Cambridge university press, 2011.
- [28] T. Altan and A. E. Tekkaya, Sheet metal forming: processes and applications: ASM international, 2012.
- [29] T. Stolarski, Y. Nakasone, and S. Yoshimoto, Engineering analysis with ANSYS software: Butterworth-Heinemann, 2018.
- [30] A. M. Al-Jassani, "Analytical and Numerical Study of Tube Drawing Through A Conical Die," Kufa Journal of Engineering, vol. 12, pp. 14-27, 2021. <https://doi.org/10.30572/2018/KJE/120402>.
- [31] Ö. SEÇGİN and V. TAŞDEMİR, "Finite element analysis of angular deep drawing process without blank holder," International Journal of Innovative Research in Applied Sciences and Engineering, pp. 2020.789-792, 2020. <https://doi.org/10.29027/IJRASE>.
- [32] R. Mohammed, Atheer, and K. Waleed Jawad. "Practical test and FEA to evaluation of the thickness distribution for octagonal cup generated by deep drawing." AIP Conference Proceedings. Vol. 3002. No. 1. AIP Publishing LLC, 2024. <https://doi.org/10.1063/5.0205959>.
- [33] M. Ahmetoglu, T. R. Broek, G. Kinzel, and T. Altan, "Control of blank holder force to eliminate wrinkling and fracture in deep-drawing rectangular parts." CIRP annals vol. 44.1 pp. 247-250, 1995. [https://doi.org/10.1016/S0007-8506\(07\)62318-X](https://doi.org/10.1016/S0007-8506(07)62318-X).
- [34] A. Asgharpour, H. Gorji, and S.E Delpazir, Experimental and numerical investigation to determine the optimal blank-holder force in deep drawing process based on forming force for SS304L and St14 sheets. Journal of the Brazilian Society of Mechanical Sciences and Engineering vol. 46, 349 2024. <https://doi.org/10.1007/s40430-024-04935-6>.
- [35] W. K. Jawad, and, A. Jaafar. "The influence of punch profile radius on deep drawing process in case of a low carbon steel cylindrical cup." Engineering and Technology Journal, Vol.36, Part A, No. 10, pp. 1048-9401, 2018. <http://dx.doi.org/10.30684/etj.36.10A.5>.
- [36] Han, Seong-Sik, and Heung-Kyu Kim. "Optimum multistage deep drawing process design using artificial neural network-based forming quality evaluation function." Journal of Materials Processing Technology Vol. 341 118881, 2025. <https://doi.org/10.1016/j.jmatprotec.2025.118881>.
- [37] Zaid, Adnan IO. "Deep drawing mechanism, parameters, defects and recent results: state of the art." IOP Conference Series: Materials Science and Engineering. Vol. 146. No. 1. IOP Publishing, 2016. <https://doi.org/10.1088/1757-899X/146/1/012009>.